

# Modicon M580 and Premium/Atrium using EcoStruxure™ Control Expert TSX ISP Y101 Weighing Module User Manual

(Original Document)

12/2018

---

The information provided in this documentation contains general descriptions and/or technical characteristics of the performance of the products contained herein. This documentation is not intended as a substitute for and is not to be used for determining suitability or reliability of these products for specific user applications. It is the duty of any such user or integrator to perform the appropriate and complete risk analysis, evaluation and testing of the products with respect to the relevant specific application or use thereof. Neither Schneider Electric nor any of its affiliates or subsidiaries shall be responsible or liable for misuse of the information contained herein. If you have any suggestions for improvements or amendments or have found errors in this publication, please notify us.

You agree not to reproduce, other than for your own personal, noncommercial use, all or part of this document on any medium whatsoever without permission of Schneider Electric, given in writing. You also agree not to establish any hypertext links to this document or its content. Schneider Electric does not grant any right or license for the personal and noncommercial use of the document or its content, except for a non-exclusive license to consult it on an "as is" basis, at your own risk. All other rights are reserved.

All pertinent state, regional, and local safety regulations must be observed when installing and using this product. For reasons of safety and to help ensure compliance with documented system data, only the manufacturer should perform repairs to components.

When devices are used for applications with technical safety requirements, the relevant instructions must be followed.

Failure to use Schneider Electric software or approved software with our hardware products may result in injury, harm, or improper operating results.

Failure to observe this information can result in injury or equipment damage.

© 2018 Schneider Electric. All rights reserved.

---

# Table of Contents

---



	<b>Safety Information</b> . . . . .	7
	<b>About the Book</b> . . . . .	9
<b>Part I</b>	<b>Introducing the TSX ISP Y101 Weighing Module</b> . . .	11
<b>Chapter 1</b>	<b>Introducing the TSX ISP Y101 Weighing Module</b> . . . . .	13
	Introducing the Premium Weighing System . . . . .	14
	Introducing the TSX ISP Y101 Weighing Module . . . . .	16
	TSX ISP Y101 Weighing Module Description . . . . .	17
	TSX ISP Y101 Weighing Module Characteristics . . . . .	18
<b>Chapter 2</b>	<b>Installing the TSX ISP Y101 Weighing Module</b> . . . . .	19
	Recommendations for Installing a Measurement System . . . . .	20
	Installing the Weighing Module . . . . .	22
	Cabling Recommendations . . . . .	24
<b>Chapter 3</b>	<b>Troubleshooting the Weighing Module</b> . . . . .	25
	Weighing Module LED Diagnostics . . . . .	26
	Weighing Module Diagnostics . . . . .	28
<b>Chapter 4</b>	<b>Weighing Module Connections</b> . . . . .	29
	Measurement Connection . . . . .	30
	Connection of Discrete Outputs of the Weighing Module . . . . .	33
	Serial Link Pins on the Display Panel . . . . .	35
	TSX XBT N410 Display Panel . . . . .	36
<b>Part II</b>	<b>Configuring and Diagnosing the TSX ISP Y101 Weighing Module</b> . . . . .	39
<b>Chapter 5</b>	<b>Introducing the Weighing Application-Specific Function</b> . . . . .	41
	Installation Phase Overview . . . . .	42
	Weighing Module Operation . . . . .	44
<b>Chapter 6</b>	<b>Configuring the Weighing Module</b> . . . . .	47
	Weighing Module Configuration Screen . . . . .	48
	Weighing Module Configuration Parameters . . . . .	50
	How to Modify the Task Parameter . . . . .	51
	How to Modify Measurement Information . . . . .	52
	How to Modify the Zero . . . . .	54
	How to Modify the Data Format . . . . .	55
	How to Modify the Stability . . . . .	56

	How to Modify Measurement Input Filter(s) . . . . .	57
	How to Modify the Flow Calculation . . . . .	59
	How to Modify the Tare . . . . .	60
	How to Modify the Threshold Check . . . . .	61
<b>Chapter 7</b>	<b>Weighing Module Language Objects . . . . .</b>	<b>65</b>
7.1	Weighing Application Programming Principles . . . . .	66
	Weighing Application Programming Principles . . . . .	67
	Addressing Language Objects Associated with the Weighing Module . . . . .	69
	Description of the Main Objects Linked to the Weighing Function. . . . .	70
7.2	Language Objects and IODDT . . . . .	72
	Presentation of Language Objects Associated with the Weighing Function . . . . .	73
	Implicit Exchange Language Objects Associated with the Application-Specific Function . . . . .	74
	Explicit Exchange Language Objects Associated with the Application-Specific Function . . . . .	75
	Management of Exchanges and Reports with Explicit Objects . . . . .	77
7.3	The IODDTs of the Weighing Module . . . . .	82
	Details of the Implicit Exchange Objects of the IODDT of Types T_WEIGHING_ISPY101 and T_WEIGHING_ISPY101_2 . . . . .	83
	Explicit Exchange Objects of the IODDT of Types T_WEIGHING_ISPY101 and T_WEIGHING_ISPY101_2 . . . . .	85
	Explicit Exchange Objects of IODDT Types T_WEIGHING_ISPY101 and T_WEIGHING_ISPY101_2 . . . . .	87
	Explicit Exchange Objects of the IODDT of Types T_WEIGHING_ISPY101 and T_WEIGHING_ISPY101_2 . . . . .	89
	Details of the Language Objects of the T_GEN_MOD-Type IODDT . . . . .	90
7.4	Description of the Commands Conveyed by the Program. . . . .	91
	Sending Commands to the Weighing Module by Program . . . . .	92
	How to Perform a Tare Mode by Program . . . . .	93
	How to Reset the Value of the Weight to Zero by Program . . . . .	95
	How to Return to Gross Weight Measurement via the Program . . . . .	97
	How to Display the Manual Tare via the Program . . . . .	98
	How to Enable or Disable Thresholds by Program . . . . .	99
7.5	Modifying the Parameters by Program. . . . .	101
	Modifying the Parameters by Program. . . . .	102
	Instructions Used for Adjustments . . . . .	104
	Description of Parameters Adjustable by Program . . . . .	106
	Reading Configuration Parameters . . . . .	107

---

<b>Chapter 8</b>	<b>Debugging the Weighing Function</b> . . . . .	<b>111</b>
	Introduction to the Debug Function of the Weighing Module. . . . .	112
	Description of the Weighing Application Function Debug Screen . . . .	113
	Description of the Module Zone of the Debug Screen. . . . .	115
	Description of the Display Zone of the Debug Screen. . . . .	116
	Description of the Parameter Setting Zone . . . . .	117
<b>Chapter 9</b>	<b>Calibrating the Scale.</b> . . . . .	<b>119</b>
	Introduction to the Calibration Function. . . . .	120
	Description of the Calibration Screen . . . . .	122
	Calibrating the Analog Measurement System . . . . .	124
	Calibrating the Analog Measurement System by Program . . . . .	126
	How to Perform a Forced Calibration . . . . .	128
	Performing a Forced Calibration by Program . . . . .	129
	How to Make a Software Calibration with a TSX ISP Y101, V2.1 . . . .	130
	How to Make a Software Calibration with a TSX ISP Y101, V2.2 or Later . . . . .	132
<b>Chapter 10</b>	<b>Protecting the Adjustments.</b> . . . . .	<b>135</b>
	Protection of the Weighing Parameter Settings. . . . .	136
	How to Protect the Adjustments . . . . .	138
	Legal Metrology and Regulations . . . . .	139
<b>Chapter 11</b>	<b>Operating a Weighing Application</b> . . . . .	<b>141</b>
	Ways of Displaying Weighing Information . . . . .	142
	Description of the Display Report . . . . .	143
	Weighing Module Operating Modes . . . . .	145
<b>Chapter 12</b>	<b>Diagnostics of the Weighing Application.</b> . . . . .	<b>147</b>
	How to Access the Diagnostics Function of the Weighing Module . . .	148
	How to Access the Channel Diagnostics Function of the Weighing Module. . . . .	149
<b>Chapter 13</b>	<b>Examples of the Weighing Program</b> . . . . .	<b>151</b>
	Example of a Tare Mode . . . . .	152
	Example of Metering Flow . . . . .	153
<b>Glossary</b>	. . . . .	<b>157</b>
<b>Index</b>	. . . . .	<b>159</b>



---

# Safety Information

---



## Important Information

### NOTICE

Read these instructions carefully, and look at the equipment to become familiar with the device before trying to install, operate, service, or maintain it. The following special messages may appear throughout this documentation or on the equipment to warn of potential hazards or to call attention to information that clarifies or simplifies a procedure.



The addition of this symbol to a “Danger” or “Warning” safety label indicates that an electrical hazard exists which will result in personal injury if the instructions are not followed.



This is the safety alert symbol. It is used to alert you to potential personal injury hazards. Obey all safety messages that follow this symbol to avoid possible injury or death.

## **DANGER**

**DANGER** indicates a hazardous situation which, if not avoided, **will result in** death or serious injury.

## **WARNING**

**WARNING** indicates a hazardous situation which, if not avoided, **could result in** death or serious injury.

## **CAUTION**

**CAUTION** indicates a hazardous situation which, if not avoided, **could result** in minor or moderate injury.

## **NOTICE**

**NOTICE** is used to address practices not related to physical injury.

---

## PLEASE NOTE

Electrical equipment should be installed, operated, serviced, and maintained only by qualified personnel. No responsibility is assumed by Schneider Electric for any consequences arising out of the use of this material.

A qualified person is one who has skills and knowledge related to the construction and operation of electrical equipment and its installation, and has received safety training to recognize and avoid the hazards involved.

---

# About the Book

---



## At a Glance

### Document Scope

This manual describes the hardware and software implementation of the TSX ISP Y101 weighing module for Modicon M580 and Premium/Atrium PLCs.

### Validity Note

This documentation is valid for EcoStruxure™ Control Expert 14.0 or later.

### Product Related Information

 <b>WARNING</b>
<b>UNINTENDED EQUIPMENT OPERATION</b> The application of this product requires expertise in the design and programming of control systems. Only persons with such expertise should be allowed to program, install, alter, and apply this product. Follow all local and national safety codes and standards. <b>Failure to follow these instructions can result in death, serious injury, or equipment damage.</b>



---

# Part I

## Introducing the TSX ISP Y101 Weighing Module

---

### Introduction

This part introduces the TSX ISP Y101 weighing module in the **Premium** and **M580** ranges.

### What Is in This Part?

This part contains the following chapters:

Chapter	Chapter Name	Page
1	Introducing the TSX ISP Y101 Weighing Module	13
2	Installing the TSX ISP Y101 Weighing Module	19
3	Troubleshooting the Weighing Module	25
4	Weighing Module Connections	29



---

# Chapter 1

## Introducing the TSX ISP Y101 Weighing Module

---

### Introduction

This chapter provides an introduction to the TSX ISP Y101 weighing module.

### What Is in This Chapter?

This chapter contains the following topics:

Topic	Page
Introducing the Premium Weighing System	14
Introducing the TSX ISP Y101 Weighing Module	16
TSX ISP Y101 Weighing Module Description	17
TSX ISP Y101 Weighing Module Characteristics	18

## Introducing the Premium Weighing System

### Introduction

The following illustration displays the Premium weighing system range.

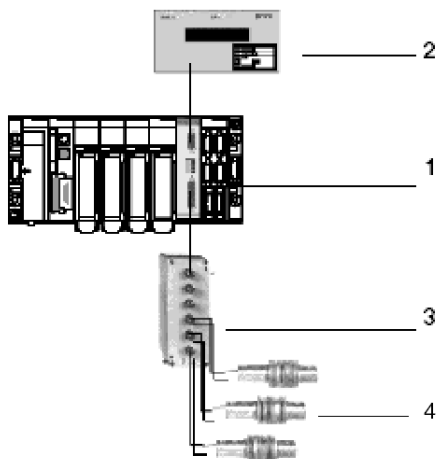

The various elements of the weighing system are described in the following table.

Number	Description
1	the <b>TSX ISP Y101</b> weighing module
2	the <b>TSX XBT N410</b> display panel with weighing protocol
3	junction box
4	weighing sensors

#### NOTE:

The complete Premium weighing range integrates the following process control applications:

- filling unit
- multi-product metering
- flow regulator
- graded weighing unit
- batch and continuous totalizer

The following illustration presents the different elements that may make up a complete weighing system configuration.

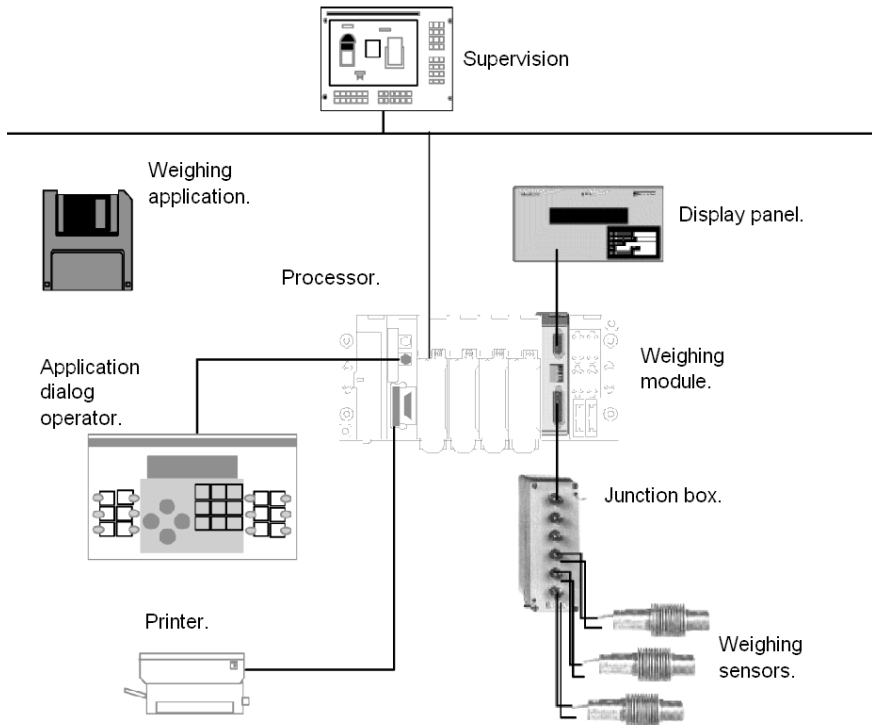

## Introducing the TSX ISP Y101 Weighing Module

### Introduction

The TSX ISP Y101 weighing module comes with:

- one *measurement input* channel capable of receiving up to 8 constraint gauge sensors
- two *discrete callback outputs* for graded filling applications
- one *sealable digital link* enabling the weight or manual tare to be displayed on a TSX XBT N410 external display panel

In order to maintain integrity of the measurements made, the measurement input, the weighing module, and the display panel can be lead sealed to meet legal metrology requirements concerning weighing instruments used in commercial transactions.

### Maximum TSX ISP Y101 Modules per Station

The maximum number of TSX ISP Y101 modules in a PLC station depends on:

- the type of processor installed (see the following table)
- the number of application-specific channels already used
- the number of application-specific channels and functions supported, which may differ between a Premium/Atrium implementation and an M580 implementation

## TSX ISP Y101 Weighing Module Description

### Introduction

The following is a physical description of the **TSX ISP Y101** weighing module.

### Illustration

The following illustration presents the **TSX ISP Y101** module.

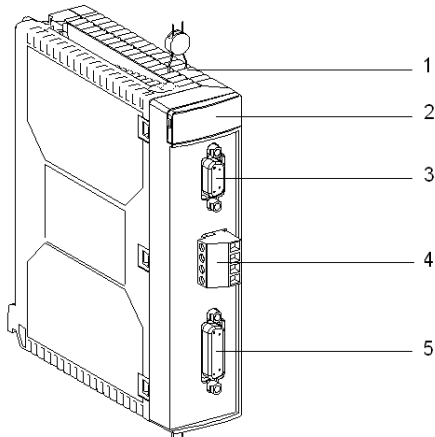

### Illustration Legend

The following table describes the different elements of the weighing module:

Number	Description
1	a plastic case equipped with shielding plates to help protect the electronic circuits and help protect against radiant interference
2	display block
3	a 9-pin Sub-D female connector for connecting the remote display ( <b>TSX XBT N410</b> )
4	a 5-pin screw terminal block for connecting discrete outputs
5	a 15-pin Sub-D female connector for connecting weighing sensors

## TSX ISP Y101 Weighing Module Characteristics

### Introduction

This part introduces the general characteristics of the **TSX ISP Y101** module.

### Characteristics

This following table provides the general characteristics of the **TSX ISP Y101** module.

<b>Electrical Range</b>	0 to 25 mV
<b>Minimum Dynamic</b>	4.5 mV
<b>Maximum Dynamic</b>	25 mV
<b>Converter Resolution</b>	24 bits (16,777,216 points)
<b>Limitations of Use</b>	50 000 pts
<b>Conversion Speed</b>	45 measurements/second
<b>Load Cell Supply Voltage</b>	5 V (switched)
<b>Load Cell Wiring Distance</b>	300 m (with no loss of precision with 4 load cells)
<b>Zero Drift</b>	< 200 nV/°C
<b>Gain Drift</b>	< 10 ppm/°C
<b>Non Linearity</b>	< 20 ppm (FS)
<b>50 Hz Series Mode Rejection</b>	> 120 dB
<b>Maximum Length of the Measurement Cable</b>	100 m for cable at 0.4 mm <sup>2</sup> 200 m for cable at 0.6 mm <sup>2</sup> For 1 to 8 sensors

### Consumption

The following table shows the consumption values of the module **TSX ISP Y101** module:

		<b>Typical</b>	<b>Maximum</b>
<b>Consumption</b>	on 5 VDC	150 mA	330 mA
	on 24 VR (1)	7 mA + 17 mA x N	14 mA + 17 mA x N
<b>Dissipated Power</b>		0.75 W	1.65 W
<b>Key:</b>			
(1)	Consumption depends on the number of sensors (N) present on the measurement input.		

---

# Chapter 2

## Installing the TSX ISP Y101 Weighing Module

---

### Introduction

This chapter presents the basic rules and guidelines for installing the weighing module.

### What Is in This Chapter?

This chapter contains the following topics:

Topic	Page
Recommendations for Installing a Measurement System	20
Installing the Weighing Module	22
Cabling Recommendations	24

## Recommendations for Installing a Measurement System

### Introduction

The quality of the measurement provided by the module may be reduced considerably if the sensor set-up and installation steps have not been observed. The following information details some of the steps to take.

### Dividing up the Loads

In a measurement system, the weighing sensors support the following weights:

- the maximum weight to be weighed
- the weight of the loading receiver and its structures (or measurement tare)

This total weight is divided up between 1, 2, 3, 4, 6, and 8 sensors. The design of the mechanical structures, the shape of the loading receiver, and the dividing of the load on or within the receiver means that the total weight may not be equally divided between the sensors (except of course in the case of a single sensor).

Confirm that the dimensions of the weighing sensors are calculated in such a way as to be able to support the total weight (maximum weight + tare) to which they will be subjected.

### Inhibiting Interference on the Load Receiver

Since a weighing sensor deflection is very weak (a few tenths of a millimeter), interference on the load receiver or any friction on the permanent framework will cause an invalid weight measurement and make correct adjustment of the module impossible.

### Mechanical Installation of the Weighing Sensors

Use the sensors in traction or compression vertically, respecting their action direction (traction or compression). The maximum admissible tolerance on the installation's verticality is in the region of the degree according to the installation and the required precision.

### Helping Protect the Sensors from Interference Currents

It is recommended that each sensor be provided with a mass flex which plays the role of the electric *shunt* with the aim of helping protect sensors from currents capable of circulating in the metallic framework (ground currents, from the terminal to be connected, and electrostatic discharges...).

This flex will be of a sufficient length to not result in mechanical constraints, and it will be placed directly next to the sensors between the permanent framework and the load receiver.

### Contact with Water and Corrosive Products

Weighing sensors are manufactured to help prevent damage from water. However, avoid coming into contact with water, corrosive products, and direct sunlight.

### Preventive Maintenance of the Installation and Accessories

The weighing module requires no special maintenance. The weighing sensors, however, should be cleaned periodically if used in a difficult environment.

Periodically test and service the mechanical state of the load receiver.

- Cleaning the receiver and its structures because of a product deposit or various material deposits may result in a noticeable variation of the tare.
- Check the verticality of the weighing sensors.
- Check the sensor and actuator states according to their period of use.
- Etc...

**NOTE:** Statistics show that 90% of breakdowns occurring on a weighing/dosing installation are not attributable to the electric command device, but to the installation itself (for example, inoperable limit switches, inoperable machinery).

## Installing the Weighing Module

### Introduction

The method and steps relating to the installation of the weighing module are detailed as follows:

### Installation

The weighing module **TSX ISP Y101** is standard format and therefore occupies a single position in the **TSX RKY...** racks. It can be installed in any position on the rack except for the first two (PS and 00) which are reserved for the rack power supply module (**TSX PSY...**) and processor module (**TSX 57...**) respectively.

They are powered by the rack back bus, and can be positioned either in the standard rack or in an extendable rack.

The installation and removal of the weighing module can be done with the PLC **switched on** (without damaging the module or disrupting the PLC).

### Installing the Module on the Rack

Installation of the weighing module on the rack is carried out as follows:

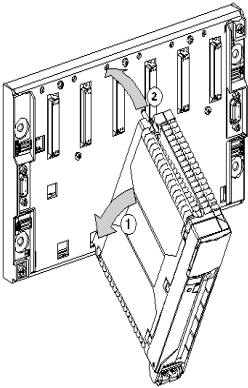
Step	Action	
1	Position the two lugs at the rear of the module (the lower part of the module) in the centering holes located on the lower part of the rack.	
2	Pivot the module upwards so as to plug it into the rack's back connector.	

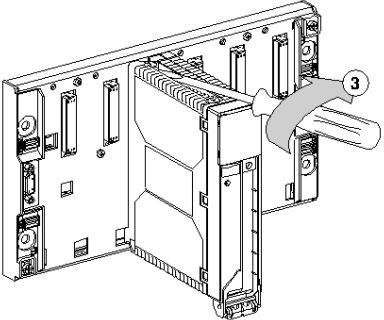
Step	Action	
3	<p>Fix the module to the rack by tightening the screw located on the upper part of the module.</p> <p><b>Note:</b> If this screw is not tightened, the module will not stay in the rack position.</p>	 A technical line drawing of a server rack with a module inserted. A grey arrow points to a screw on the top edge of the module, which is labeled with the number '3'. The diagram shows the module's front panel and its connection to the rack's backplane.

## Cabling Recommendations

### Introduction

To help protect the signal from external noises induced in serial mode and from noises in common mode, follow these instructions.

### Kind of Conductors

Use shielded twisted pairs of a minimum section of 0.28 mm<sup>2</sup> (AWG24 gage).

### Cable Shielding

Connect the measurement cable shielding to the ground on the module side only. You can also connect both ends of the shield to the ground if the grounds on either side of the connection are of good quality.

On the Sub-D connectors, connect the cable shield to the cover of the connector, the PLC ground being connected by the tightening screws of the Sub-D connector. For this reason, the male Sub-D connector is screwed onto its female connection base.

### Cable Routing

Keep the measurement wires as far as possible from the discrete input/output cables (particularly relay outputs) and the cables which transmit "power" signals.

Instead of parallel routing (maintain a distance of at least 20 cm between the cables), cross them at right angles.

**NOTE:** The measurement input is grounded via the module.

---

# Chapter 3

## Troubleshooting the Weighing Module

---

### Introduction

This chapter presents guidelines for troubleshooting the weighing module.

### What Is in This Chapter?

This chapter contains the following topics:

Topic	Page
Weighing Module LED Diagnostics	26
Weighing Module Diagnostics	28

## Weighing Module LED Diagnostics

### Introduction

The weighing module is fitted with LEDs, which display the status of the module and the status of the channels. We distinguish between the:

- module status LEDs: RUN, ERR and I/O
- channel status LEDs: CH•

### Illustration

The following diagram shows the weighing module display screen:

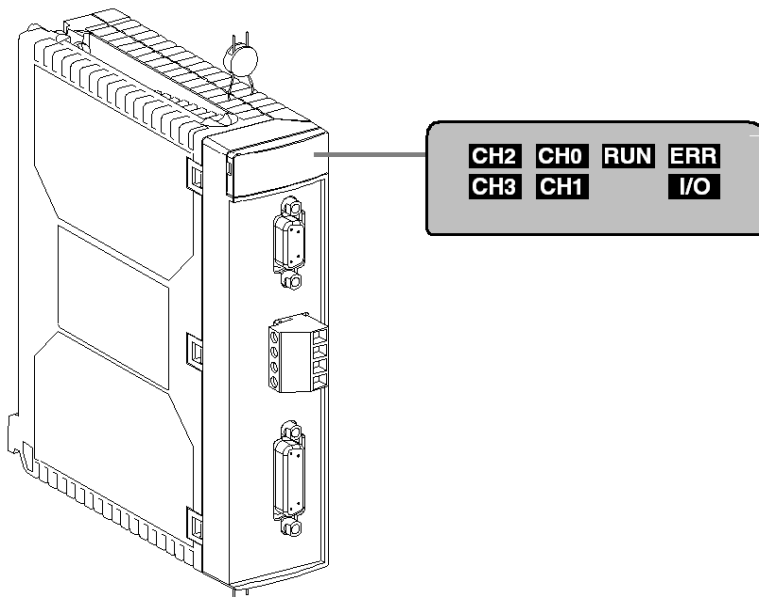



## Description

Three LEDs located on the display panel of each module indicate the operational status of the module (LED on, flashing and off):

- The green LED RUN indicates the module's operational status.
- The red LED ERR indicates a detected internal error in the module or a detected error between the module and the rest of the configuration.
- The red LED I/O indicates a detected external error.

The various possible detected errors are grouped in the following table:

LED	 On	 Flashing	 Off
<b>RUN (green)</b>	Normal operation	-	Module inoperative or switched off
<b>ERR (red)</b>	Detected internal error, module inoperative	Detected communication error, missing or invalid application or detected error in application	No detected internal error
<b>I/O (red)</b>	Detected external errors: <ul style="list-style-type: none"> <li>● overload or underload during calibration</li> <li>● range overshoot</li> <li>● measurement</li> <li>● configuration refused by module</li> </ul>	No connection to the weighing sensors.	No detected external error
<b>CHO</b>		Module has not been calibrated (new module) or is performing a forced calibration.  <b>NOTE:</b> None of the other channels have status LEDs.	

## Weighing Module Diagnostics

### Introduction

A module with detected errors indicates them by means of the RUN, ERR and I/O LEDs.

There are three groups of detected errors: external, internal and others.

### Detected Error Diagnostics

The following table can be used to diagnose the detected errors using the three LEDs: RUN, ERR and I/O:

Module Status	Status of LEDs		
	RUN	ERR	I/O
Normal operation	●	○	○
Module performing a forced calibration		⊗	
Module inoperative or switched off	○	⊗	○
Internal detected error (module inoperative):			
● with communication to the CPU	●	●	○
● without communication to the CPU	○	●	○
External detected errors:			
● overload or underload during calibration			
● range overshoot			
● measurement	●	○	●
● configuration refused			
Other detected communication errors:			
● application is absent)	●	⊗	○
● application is invalid			
<b>Key:</b>			
○ LED unlit			
⊗ LED flashing			
● LED lit			

---

# Chapter 4

## Weighing Module Connections

---

### Introduction

This chapter describes the weighing module connections.

### What Is in This Chapter?

This chapter contains the following topics:

Topic	Page
Measurement Connection	30
Connection of Discrete Outputs of the Weighing Module	33
Serial Link Pins on the Display Panel	35
TSX XBT N410 Display Panel	36

## Measurement Connection

### Introduction

The measurement sensors are connected using a 15-pin female Sub-D connector on the module side.

TSX ISP Y101

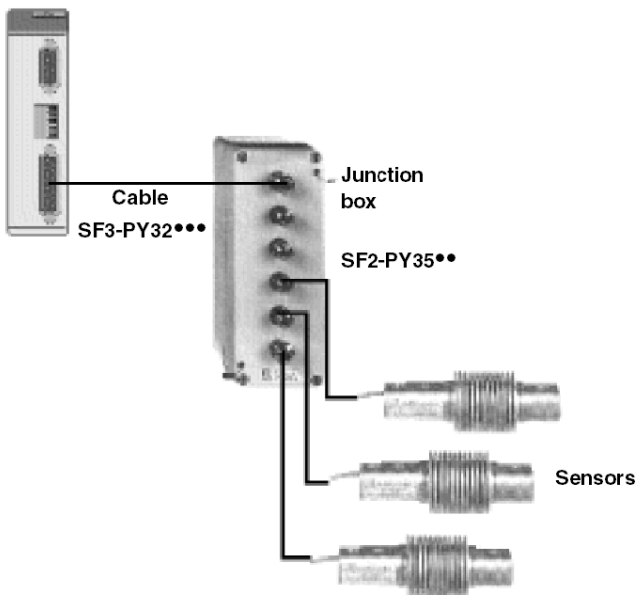

The module and the Sub-Ds can be plugged-in and unplugged with the power on.

Use a 6 conductor cable with a 15-pin Sub-D connector.

Sensor supply is exclusively provided by the module.

## Sub-D Connector 15

Connection of the 15-pin Sub-D connector is shown in the following illustration:

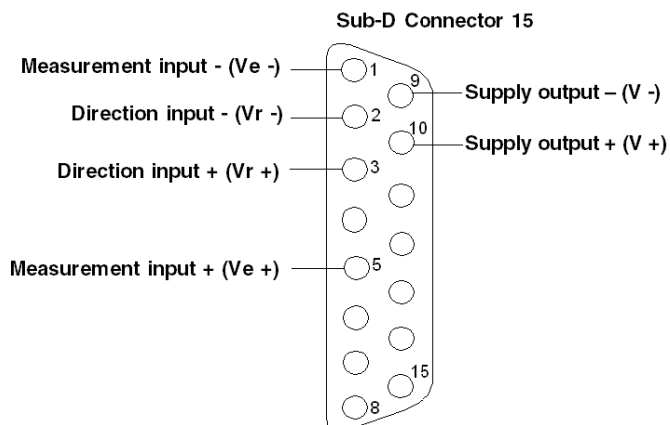

## Cabling Sensor Inputs

Depending on the accuracy desired, there are two ways to cable the sensor inputs. **In each case, cable them in order to obtain a measurement.**

High accuracy cabling or where the length of the cable between the module and the sensor connection unit is great:

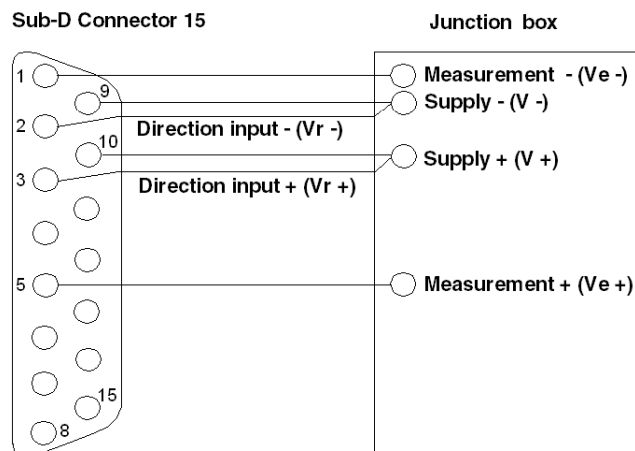

Average accuracy cabling or where the length of the cable between the module and the sensors connection is not great:

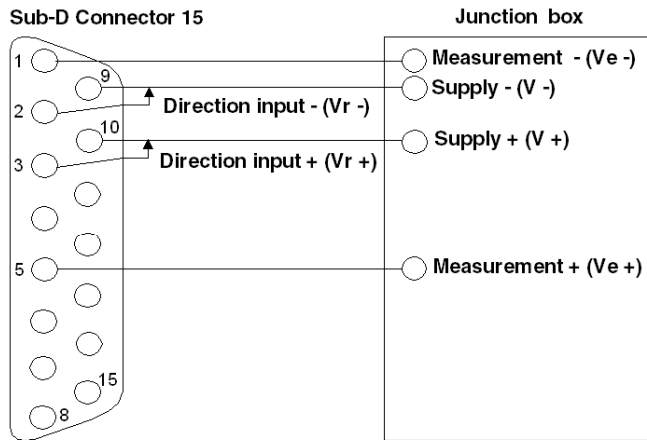

## Connection of Discrete Outputs of the Weighing Module

### Introduction

Weighing module discrete outputs are used to trigger actions on threshold crossings. This functionality is used in the "filling unit" application.

Discrete outputs are connected using a screw terminal block:

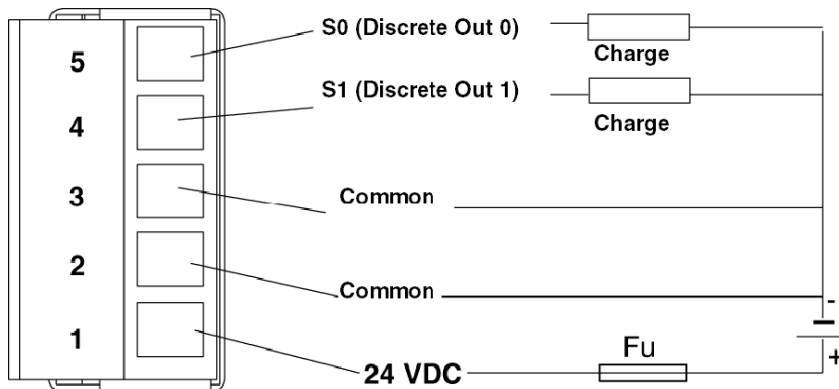

The common 2 and 3 are linked by the card.

### Discrete Output Characteristics

The following table shows the characteristics of the discrete outputs of the module **TSX ISP Y101**:

Discrete Output	Characteristics
<b>Number of Channels</b>	2
<b>Type</b>	A transistors
<b>Response Time</b>	1 ms discrimination. The threshold crossover point between two measurements is calculated by interpolation to the millisecond.
<b>Nominal Supply Voltage</b>	24 V
<b>Insulation Voltage</b>	1500 Vrms
<b>Maximum Current</b>	500 mA
<b>Protection</b>	Reverse polarity and short circuit. Install a fuse on the +24 V pre-actuator supply.

## Protection

The ground connection galvanically helps protect the 2 output channels against:

- short-circuits and overloads
- reverse polarities

**NOTE:** In order to help protect against reverse polarities, place a fast-acting **fuse** on the supply, upstream of the load (shown as Fu in the previous diagram).

## Serial Link Pins on the Display Panel

### Introduction

The serial link is used to carry over the weight to an external display panel.

The connection to the terminal is via a female 9 pin Sub-D connector on the module side, the link is RS485, the connections are described below :

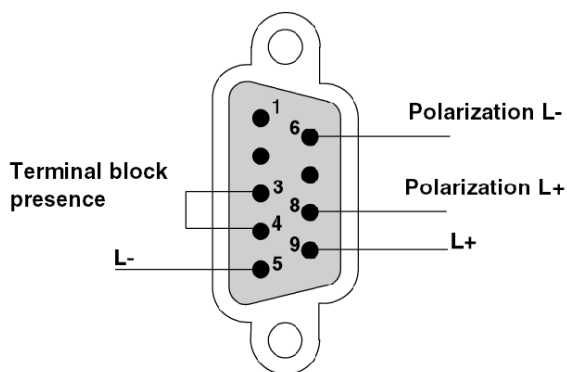

The line on the module side is polarized using straps 6-5 and 8-9.

### Characteristics

The following table shows the characteristics of output display panel :

Output Display Panel	Characteristics
<b>Physical Interface</b>	non-isolated RS 485
<b>Bit Rate</b>	9,6 Kbits/s
<b>Format</b>	1 start bit, 8 data bits and 1 stop bit
<b>Remote Distance</b>	Maximum 30 m

## TSX XBT N410 Display Panel

### Introduction

The **TSX XBT N410** is designed to be connected to the weighing module, in order to act as the main display panel and display weight information.

The display panel should be connected to the module by a shielded cable with two conductors. It is equipped with a 15-pin female SUB-D connector.

### Characteristics

The following table shows the electrical characteristics of the display panel:

<b>Display</b>	Green back-lit LCD (122x32 pixels)	
<b>Display Capacity</b>	2 lines of 20 characters	
<b>Refresh Period</b>	100 ms	
<b>Serial Link</b>	RS 485	
<b>Transmission Speed</b>	9.6 Kbits/s	
<b>Connection</b>	With 25-way SUB-D connector	
<b>Power Supply</b>	Plug-in terminal block, 3 screw terminal (pitched at 5.08 mm [0.2 in]). Maximum clamping capacity: 1.5 mm (0.06 in).	
<b>Voltage Limits</b>	18 to 30 V, DC	
<b>Ripple</b>	5% maximum	
<b>Consumption</b>	5 W maximum	
<b>Ambient Temperatures</b>	for operation	0...55°C (32...130°F)
	for storage	-20...60°C (-4...140°F)
<b>Degree of Protection</b>	front	IP65 and in compliance with IEC 60529 and Nema 4X ("outdoor use")
	rear	IP20, in compliance with IEC 60529
<b>Compliant with Standards</b>	IEC 61131-2, IEC 60068-2-6, IEC 60068-2-27, UL 508 and CSA C22-2 No.14	

## Display Panel Connections

The following diagram shows the link between the **TSX ISP Y101** weighing module and the **TSX XBT N410** display panel:

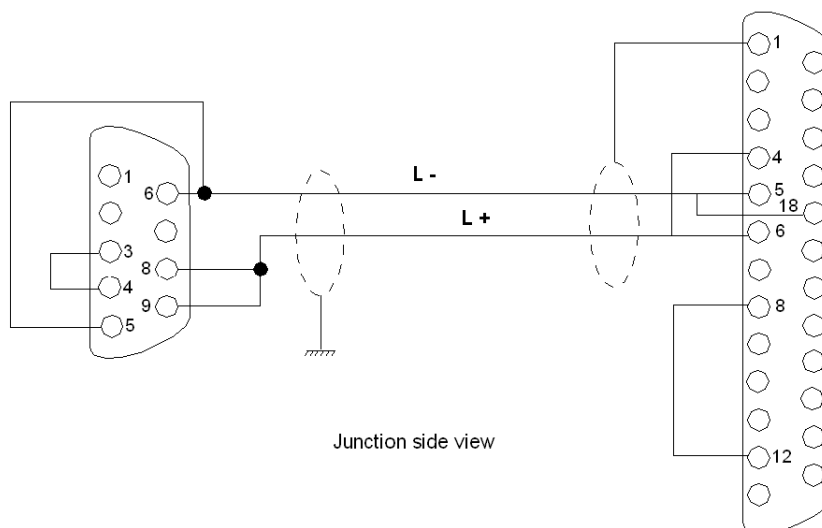

The cable, a **shielded twisted pair**, from the weighing module to the **TSX XBT N410** cannot exceed 100 meters (328 feet).

The shield on the module side should be connected to the metal part of the SUB-D connector.

## List of Cables

The following table provides the reference and length of each cable.

Reference	Length, m (ft)
SF3 CPY005	5 (16.4)
SF3 CPY010	10 (32.8)
SF3 CPY015	15 (49.2)
SF3 CPY020	20 (65.6)
SF3 CPY025	25 (82.0)
SF3 CPY030	30 (98.4)



---

## Part II

# Configuring and Diagnosing the TSX ISP Y101 Weighing Module

---

### Introduction

This part describes the TSX ISP Y101 weighing application-specific function in the **Premium** and **M580** ranges, and describes its installation with Control Expert.

### What Is in This Part?

This part contains the following chapters:

Chapter	Chapter Name	Page
5	Introducing the Weighing Application-Specific Function	41
6	Configuring the Weighing Module	47
7	Weighing Module Language Objects	65
8	Debugging the Weighing Function	111
9	Calibrating the Scale	119
10	Protecting the Adjustments	135
11	Operating a Weighing Application	141
12	Diagnostics of the Weighing Application	147
13	Examples of the Weighing Program	151



---

# Chapter 5

## Introducing the Weighing Application-Specific Function

---

### Introduction

This section introduces the weighing application-specific function on Premium PLCs.

### What Is in This Chapter?

This chapter contains the following topics:

Topic	Page
Installation Phase Overview	42
Weighing Module Operation	44

## Installation Phase Overview

### Introduction

The software installation of the application-specific modules is carried out from the various Control Expert editors:

- in offline mode
- in online mode

If you do not have a processor to connect to, Control Expert allows you to carry out an initial test using the simulator. In this case the installation (*see page 43*) is different.

The following order of installation phases is recommended but it is possible to change the order of certain phases (for example, starting with the configuration phase).

### Installation Phases with Processor

The following table shows the various phases of installation with the processor:

Phase	Description	Mode
Declaration of variables	Declaration of IODDT-type variables for the application-specific modules and variables of the project.	Offline (1)
Programming	Project programming.	Offline (1)
Configuration	Declaration of modules.	Offline
	Module channel configuration.	
	Entry of configuration parameters.	
Association	Association of IODDTs with the channels configured (variable editor).	Offline (1)
Generation	Project generation (analysis and editing of links).	Offline
Transfer	Transfer project to PLC.	Online
Adjustment/Debugging	Project debugging from debug screens, animation tables.	Online
	Modifying the program and adjustment parameters.	
Documentation	Building documentation file and printing miscellaneous information relating to the project.	Online (1)
Operation/Diagnostic	Displaying miscellaneous information necessary for supervisory control of the project.	Online
	Diagnostic of project and modules.	
<b>Key:</b>		
(1)	These various phases can also be performed in the other mode.	

## Implementation Phases with Simulator

The following table shows the various phases of installation with the simulator.

Phase	Description	Mode
Declaration of variables	Declaration of IODDT-type variables for the application-specific modules and variables of the project.	Offline (1)
Programming	Project programming.	Offline (1)
Configuration	Declaration of modules.	Offline
	Module channel configuration.	
	Entry of configuration parameters.	
Association	Association of IODDTs with the modules configured (variable editor).	Offline (1)
Generation	Project generation (analysis and editing of links).	Offline
Transfer	Transfer project to simulator.	Online
Simulation	Program simulation without inputs/outputs.	Online
Adjustment/Debugging	Project debugging from debug screens, animation tables.	Online
	Modifying the program and adjustment parameters.	
<b>Key:</b>		
(1)	These various phases can also be performed in the other mode.	

**NOTE:** The simulator is only used for the discrete or analog modules.

## Weighing Module Operation

### Introduction

In the PLC environment, the module uses, in the same way as other modules, a set of data which are specific to it.

This information is used for the exchanges (report and commands) with the processor.

### Structural Diagram

The following operation diagram shows the processes executed by the module and the elements to be configured.

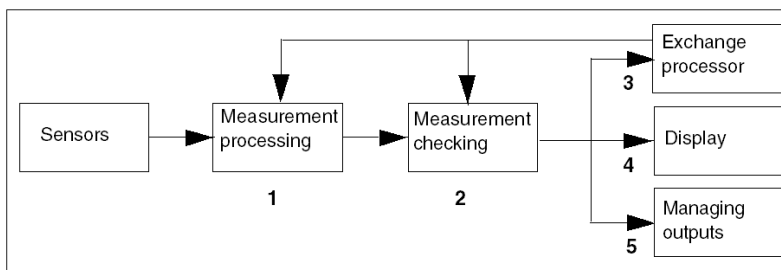

### Description of Operation

The following table describes the various operating phases of the module.

Phase	Operation	Description
1	measurement processing	The signal from the weighing sensors is: <ul style="list-style-type: none"> <li>● converted,</li> <li>● filtered according to the choice made in the configuration screen,</li> <li>● scaled, the scaling characteristics are determined at the end of a calibration.</li> </ul>
2	measurement checking	The measurement taken from the processing is subject to the following checks: <ul style="list-style-type: none"> <li>● a underload or overload check,</li> <li>● a stability check defined by a stability range and a stability time,</li> <li>● a check for presence in the zero zone.</li> </ul>
3	data exchanges with the processor	The module receives and processes the commands from the processor (Set to zero, tare mode semi automatic, etc.). It also prepares the data in legal format for display on the <b>TSX XBT N410</b> . It returns various information to the processor such as the gross weight, the net weight, the flow, the tare and the statuses.
4	data display	The <b>TSX XBT N410</b> displays the weight or the manual tare, in the unit chosen in the configuration and 4 items of additional information: the net weight, the stability, the presence in the zero zone and the unit of weight.

---

Phase	Operation	Description
5	output management	<p>The card can directly manage 2 discrete outputs and control them according to thresholds transmitted to the module by the application program.</p> <p>The elements used for this management are:</p> <ul style="list-style-type: none"><li>● the switchover thresholds,</li><li>● the direction of movement of the weight (Weighing or Downweighing),</li><li>● the switchover logic of the outputs.</li></ul>



---

# Chapter 6

## Configuring the Weighing Module

---

### Introduction

This chapter describes how to select and modify the parameters of the weighing module's configuration.

### What Is in This Chapter?

This chapter contains the following topics:

Topic	Page
Weighing Module Configuration Screen	48
Weighing Module Configuration Parameters	50
How to Modify the Task Parameter	51
How to Modify Measurement Information	52
How to Modify the Zero	54
How to Modify the Data Format	55
How to Modify the Stability	56
How to Modify Measurement Input Filter(s)	57
How to Modify the Flow Calculation	59
How to Modify the Tare	60
How to Modify the Threshold Check	61

## Weighing Module Configuration Screen

### Introduction

Configuration (see *EcoStruxure™ Control Expert, Operating Modes*) information is used to define the measuring characteristics and to adapt the operation of the module to the application for which it is intended.

### Illustration

This screen allows you to display and modify parameters in offline mode, as well as to debug in online mode.

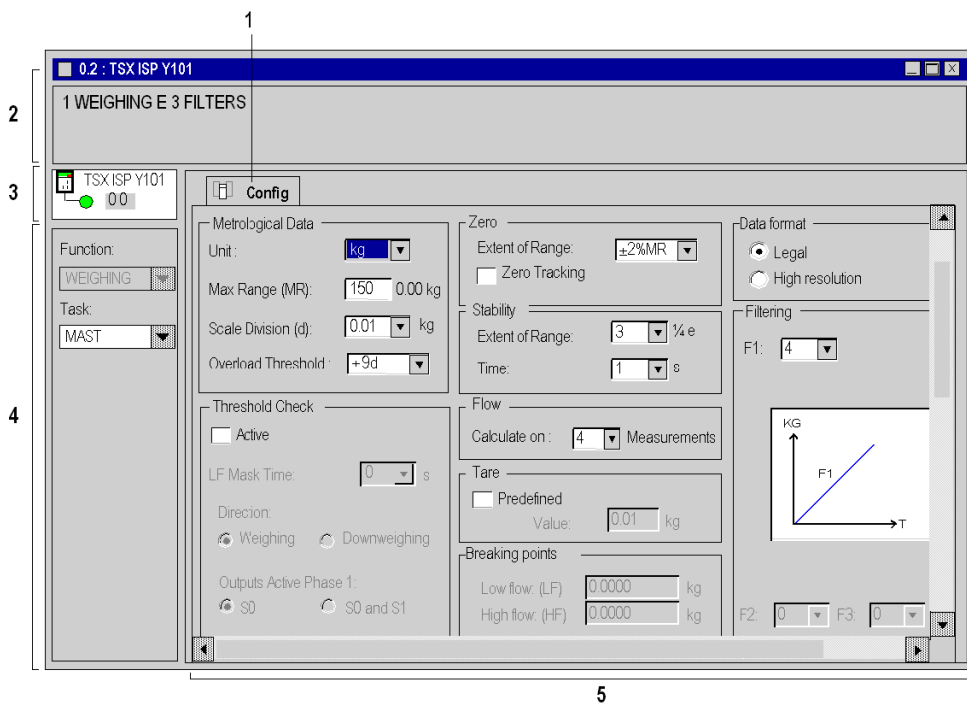

## Illustration Legend

The following table shows the various elements of the configuration screen and their functions.

Address	Element	Function
1	Tabs	The front tab indicates the current mode ( <b>Configuration</b> in this example). Each mode may be selected by the corresponding tab. The <b>Debug</b> and <b>Calibration</b> modes are only accessible in online mode.
2	<b>Module</b> zone	Shows the abbreviated name of the module. In online mode, this zone also contains the three LEDs <b>Run</b> , <b>Err</b> and <b>IO</b> .
3	<b>Channel</b> field	Is used: <ul style="list-style-type: none"> <li>● By clicking on the reference number, to display the tabs: <ul style="list-style-type: none"> <li>○ <b>Description</b> which gives the characteristics of the device.</li> <li>○ <b>I/O Objects</b> (see <i>EcoStruxure™ Control Expert, Operating Modes</i>) which is used to presymbolize the input/output objects.</li> <li>○ <b>Fault</b> which shows the diagnostic errors detected by the device (in online mode).</li> </ul> </li> <li>● To select the channel,</li> <li>● To display the <b>Symbol</b>, name of the channel defined by the user (using the variable editor).</li> </ul>
4	<b>General parameters</b> zone	Comprises: <ul style="list-style-type: none"> <li>● the dropdown <b>Function</b> menu,</li> <li>● the dropdown <b>Task</b> menu defining the task (<b>MAST</b> or <b>FAST</b>) in which the implicit exchange objects of the channels will be exchanged.</li> </ul>
5	<b>Configuration</b> zone	Is used to configure the various channels' configuration parameters.

## Weighing Module Configuration Parameters

### Configuration Parameters

The following table shows the parameters available for the weighing module.

Parameters	Possible Choices	Unit of Measurement
<b>Task</b>	<b>Mast</b> /Fast	-
<b>Metrology/Unit</b>	<b>kg</b>	kilogram
	<b>g</b>	gram
	<b>t</b>	tonne (metric)
	<b>lb</b>	pound (= 453 g)
	<b>oz</b>	ounce (= 28.35 g)
	<none>	-
<b>Metrology / Max Range</b>	from 0 to 65535 ( <b>150</b> )	in the weight unit chosen
<b>Metrology / Scale Division</b>	$1 \times 10^n$ ( $1 \times 10^{-2} = 0.01$ )	in the weight unit chosen
	$2 \times 10^n$	
	$5 \times 10^n$	
<b>Metrology / Overload Threshold</b>	<b>+9 e</b>	scale divisions
	+2 % PM	% of Max range
	+5 % PM	% of Max range
<b>Zero / Zero Tracking</b>	<b>Inactive</b> /active	-
<b>Zero / Extent of Range</b>	<b>+/-2 % PM</b> or +/-5 % PM	-
<b>Data Format</b>	<b>Legal</b> /High resolution	-
<b>Stability / Extent of Range</b>	2, <b>3</b> , 4, 6 or 8	1/4 of the scale division
<b>Stability / Time</b>	0.4, 0.5, 0.7 or <b>1</b>	seconds
<b>Filtering / Coefficients</b>	F1	from 0 to 19 ( <b>4</b> )
	F2, F3	from 0 to 19 ( <b>0</b> )
<b>Flow / Calculation</b>	2, <b>4</b> , 8, 16, 32 or 64	measurements
<b>Tare</b>	<b>Not predefined</b> /predefined	in the weight unit chosen
<b>Threshold Check</b>	<b>Inactive</b> /Active	-
<b>LF Mask Time</b>	<b>0</b> to 1.5 s per 0.1 s step	seconds
<b>Output Logic</b>	<b>Weighing</b> /Downweighing	-
<b>Phase 1 Active Outputs</b>	<b>S0</b> or (S0 and S1)	-
<b>Breaking Points PD and GD</b>	from <b>0</b> to Max Range	in 1/100ths of the unit

**NOTE:** The parameters in bold correspond to the parameters configured by default.

## How to Modify the Task Parameter

### Introduction

This parameter defines the processor task in which the input acquisition and the output update take place.

Possible choices are:

- the **MAST** task
- the **FAST** task

**NOTE:** You can configure this parameter in offline mode only.

### Procedure

The following table shows the procedure to define the type of task assigned to the module channels.

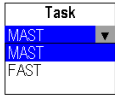
Step	Action
1	Access the weighing module configuration screen.
2	Click the <b>Task</b> drop-down menu button in the <b>General parameters</b> zone. <b>Result:</b> A drop-down list appears. 
3	Select the required task.
4	Confirm the modification with the command <b>Edit → Validate</b> .

## How to Modify Measurement Information

### Introduction

The configuration screen offers the following measurement information.

Designation	Description
<b>Unit</b>	<p>gives the choice for the weight measurement unit:</p> <ul style="list-style-type: none"> <li>● <b>g</b>: gram</li> <li>● <b>kg</b>: kilogram</li> <li>● <b>t</b>: tonne (metric)</li> <li>● <b>lb</b>: pound (lb = 453 g)</li> <li>● <b>oz</b>: ounce (oz = 28.35 g)</li> <li>● <b>without</b>: any unit</li> </ul>
<b>Max Range (MR)</b>	<p>This is the maximum weight that it is possible to weigh with the instrument and without including the weight of the empty load receiver (in the legal format <i>(see page 55)</i>).</p>
<b>Scale Division</b>	<p>The value of the scale division is in the form of 1, 2 or 5 multiplied by <math>10^n</math> (n being a positive or negative integer or zero with its absolute value <math>\leq 3</math>).</p> <p><b>Example:</b> for a scale division of 0.002 (if the unit chosen is the kg), the measurement increases by 2 g at a time.</p>
<b>Overload Threshold</b>	<p>The threshold is the value of the weight above which the display panel no longer indicates the weight (the overload is then indicated with a &gt; line on the display panel). It may take the values:</p> <ul style="list-style-type: none"> <li>● +9 scale divisions</li> <li>● +2 % of the maximum range</li> <li>● +5 % of the maximum range</li> </ul> <p><b>Example:</b> the maximum range has been established at 150 kg, the scale division at 10 g, according to the choice of the user, the operating limit will be for:</p> <ul style="list-style-type: none"> <li>● 9 e: Max range + 9 scale divisions i.e. 150.09 kg</li> <li>● +2 %MR: 102 % of Max range i.e. 153 kg</li> <li>● +5 %MR: 105 % Max range i.e. 157.5 kg</li> </ul> <p><b>Note:</b> The under-load threshold cannot be parameterized: it defines the permissible limit of the indication below zero. It is -2 % of the maximum range (the under-load is then indicated with a &lt; line on the display panel).</p>

**NOTE:** In an industrial context, because of the environment of the weighing installation, choosing a resolution of more than 3000 points assumes that there are rigorous steps to perform before installation.

At the level of the programming screen, it will not be possible to input a resolution greater than 50 000 points. In other words the following disparity should be observed: Maximum Range (MR)  $\leq 50000 \times$  Scale division.

## Procedure

The following table shows the procedure for defining the metrological information.

Step	Action
1	Access the weighing module configuration screen.
2	Select the parameter values <b>Unit</b> , <b>Scale division</b> or <b>Threshold overload</b> using the drop-down lists offered and enter the <b>Maximum Range</b> value.
3	Confirm the modification with the command <b>Edit → Validate</b> .

## How to Modify the Zero

### Introduction

The configuration screen offers the following information for zero setting.

Designation	Description
Extent of the Recalibration Range	Any deviation from zero can be corrected as long as it does not exceed this range. It is defined as a % of the maximum range. It may take the values: <ul style="list-style-type: none"> <li>● +/-2 % PM (+/- 2 % of the maximum range)</li> <li>● +/-5 % PM (+/-5 % of the maximum range)</li> </ul>
Zero Tracking	This optional function is used to compensate for slow deviations from zero in the extent of range (+/-2 % of the maximum range). You are not advised to choose this option in the automatic installations.

**NOTE:** The discrimination between a slow deviation and a true weight is based on the following rule: any variation in weight lower than the semi-scale division whose repetition frequency is sufficiently weak to preserve the stability of the measurement is considered to be a deviation. The correction engendered by the function is limited to +/-2 % of the maximum range of the flip-flop. When this limit is exceeded, there is no automatic correction.

### Procedure

The following table shows the procedure for defining zero.

Step	Action
1	Access the weighing module configuration screen.
2	Select the extent of range by using the drop-down menu.
3	If necessary, check the <b>Zero tracking</b> box to confirm this function.
4	Confirm the modification with the command <b>Edit → Validate</b> .

## How to Modify the Data Format

### Introduction

The configuration screen allows you to choose the measurement's display format.

You may enter the weight value:

- either as a fixed point physical unit: **Legal** format
- or as a hundredth of a fixed point physical unit: **High resolution**

**NOTE:** A fixed point physical unit is called a whole number expressed as a unit of weight where a point can be put. The position of this is given by the power of ten of the scale division.

### Example

**Legal format:** The value 3014 means 301.4 kg if the scale is  $2 \cdot 10^{-1}$  kg.

**High resolution format:** The value 301403 means 301,403 kg if the scale is  $2 \cdot 10^{-1}$  kg. This unit offers greater accuracy but it is not accepted by the Legal Metrology Department.

### Procedure

The following table shows the procedure for modifying the data format.

Step	Action
1	Access the weighing module configuration screen.
2	Check the data format required.
3	Confirm the modification with the command <b>Edit → Validate</b> .

## How to Modify the Stability

### Introduction

The configuration screen offers the following parameters to define the stability.

Designation	Description
<b>Extent of Range</b>	A weight cannot be measured immediately after receiving a load because the inevitable oscillations affect the mechanical part. The stability range shows the size below which the measurement is considered stable. It is parameterized on 2, 3, 4, 6, or 8 quarters of a scale.
<b>Time</b>	The stability time shows how long the measurement stays in the stability range before it is considered stable. It is parameterized on 0.4, 0.5, 0.7, or 1 second.

### Procedure

The following table shows the procedure for defining the stability.

Step	Action
1	Access the weighing module configuration screen.
2	Select the extent of range using the drop-down menu <b>Extent of range</b> in the <b>Stability</b> field.
3	Select the stability time using the drop-down menu <b>Time</b> in the <b>Stability</b> field.
4	Confirm the modification with the command <b>Edit → Validate</b> .

## How to Modify Measurement Input Filter(s)

### Introduction

Filters concern the measurement input of the weighing sensors.

By default, a unique filter is offered which is defined for the total duration of the weighing action.

To increase the speed/precision performance of weighing, 3 different filters can be used for the same weighing action, as follows:

- filter **F1** associated with phase 1 (default phase)
- filter **F2** associated with phase 2
- filter **F3** associated with phase 3

Each filter can either have:

- a sliding average (filtering coefficients from 1 to 11), where the measurement is the average of the last n values
- or be of second order (filtering coefficients from 12 to 19), which are referenced by their cut-off frequencies

### Measurement Phases

The various phases of a continuous weighing action can be broken down into:

- a phase 1, where speed is the prime feature of control precision (High flow)
- a measurement refining phase 2 (Low flow)
- a final phase 3, where the measurement value differs very little and requires a high level of precision (Residual flow)

### Filter Coefficients

The following list gives the meanings of the filter coefficients:

Value	Filter Type	Characteristics
0	none	not filtered
1	sliding average	average of the last 2 measurements
2	sliding average	average of the last 3 measurements
3	sliding average	average of the last 4 measurements
4	sliding average	average of the last 5 measurements
5	sliding average	average of the last 8 measurements
6	sliding average	average of the last 16 measurements
7	sliding average	average of the last 25 measurements
8	sliding average	average of the last 32 measurements
9	sliding average	average of the last 40 measurements
10	sliding average	average of the last 50 measurements

Value	Filter Type	Characteristics
11	sliding average	average of the last 64 measurements
12	second order filter	cut-off frequency at 15 Hz
13	second order filter	cut-off frequency at 10 Hz
14	second order filter	cut-off frequency at 8 Hz
15	second order filter	cut-off frequency at 6 Hz
16	second order filter	cut-off frequency at 4 Hz
17	second order filter	cut-off frequency at 2 Hz
18	second order filter	cut-off frequency at 1 Hz
19	second order filter	cut-off frequency at 0.8 Hz

### Procedure

The following table shows the procedure for defining the filter:

Step	Action
1	Access the weighing module configuration screen.
2	If filters F2 et F3 are being used check the <b>Active</b> box in the <b>Threshold check</b> field.
3	Select for each phase, the filtering coefficient using the drop-down menus <b>F1</b> , <b>F2</b> and <b>F3</b> in the <b>Filtering</b> field.
4	Confirm the modification with the command <b>Edit → Validate</b> .

## How to Modify the Flow Calculation

### Introduction

You can choose the number of measurements for calculating the flow. (One measurement is taken every 20 milli-seconds).

The flow is a difference in the values of filtered weights for a number of configured measurements. The flow is calculated using the following formula:

$$\text{Flow } n = \text{Val } n - (\text{Val } n-b)$$

where:

- $b$  = the number of measurements for calculating the flow
- $\text{Val } n$  = the filtered weight value at the moment  $n$
- $\text{Val } n-b$  = the filtered weight value at the moment  $n-b$

### Operation

At each instant, the frequency is calculated and implicitly sent back to the processor as the weight measurement, in order to allow threshold corrections.

The flow is calculated in high resolution format.

This calculation can be done on 2, 4, 8, 16, 32 or 64 measurements.

By default, the number of measurements is 4.

### Example

The following figure illustrates a calculation on 4 measurements.

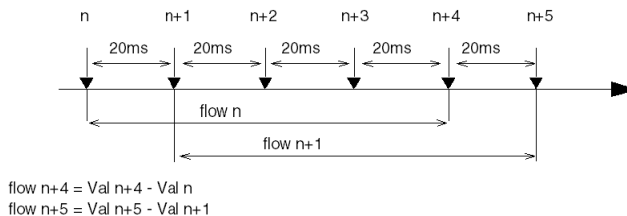

### Procedure

The following table shows the procedure for defining flow calculation.

Step	Action
1	Access the weighing module configuration screen.
2	Select the number of measurements using the drop-down menu from the <b>Flow</b> field.
3	Confirm the modification with the command <b>Edit → Validate</b> .

## How to Modify the Tare

### Introduction

The tare is the weight measurement memorized during the last semi-automatic tare unit command. However, if necessary, you can introduce a tare value manually. Therefore, this tare value is known as predefined or manual and can be transmitted to the module. It is expressed in legal format (physical unit with fixed decimal point).

Confirm that the tare is positive and lower than the Max. Range.

Once a device of this sort is used, the predefined tare (PT) indicator is positioned. It is disabled once a **Taring** order is executed.

**NOTE:** The entry range extends from 1 to 65535. If you want a greater tare, modify the scale and enter the tare accordingly.

### Procedure

The following table shows the procedure for defining a predetermined tare and the tare value.

Step	Action
1	Access the weighing module configuration screen in local mode.
2	If necessary check the <b>Predetermined</b> box in the <b>Tare</b> field to confirm this function. <b>Note:</b> If this box is already checked, first: <ul style="list-style-type: none"><li>● uncheck this box</li><li>● enable the configuration screen</li><li>● check the <b>Predefined</b> box again</li></ul>
3	Enter the tare value in the <b>Value</b> entry field.
4	Confirm the modification with the command <b>Edit</b> → <b>Validate</b> .

## How to Modify the Threshold Check

### Introduction

The threshold check manages the module's discrete outputs:

- The **High Flow cut-off point** is associated with output S0.
- The **Low Flow cut-off point** is associated with output S1.

The configuration screen gives the following threshold check information.

Designation	Description
Active	Discrete output management is operational if this box is checked. It is not checked by default.
Direction	The detection direction corresponds to the direction in which the thresholds are recognized, i.e.: <ul style="list-style-type: none"> <li>• <b>Weighing</b> (filling)</li> <li>• <b>Downweighing</b> (emptying)</li> </ul> This is the concept of exceeding by a greater value, in the case of weighing, or by a lower value, in the case of downweighing. By default, <b>Weighing</b> is selected.
Phase 1 Active Outputs	The choice concerns the control of the <b>S0</b> output on its own, or the <b>S0</b> and <b>S1</b> outputs at the same time. See the explanation that follows. By default, the module only activates <b>S0</b> in the first phase.
Cut-off Points	The measurement can be associated with 2 thresholds for the following dosages: A <b>High Flow cut-off point</b> and a <b>Low Flow cut-off point</b> . Depending on the logic defined, the <b>S0</b> and <b>S1</b> outputs go to zero when these thresholds are met. The threshold values allowed lie between 0 and the maximum range. They are expressed in high resolution (one hundredth of a physical unit with fixed decimal point).
LF (Low Flow) Mask Time	It defines the time after the high flow cut-off, during which the module no longer checks the Weight/Threshold; This is to mask the overshoot caused when the product has a drop in voltage. The values allowed lie between 0 and 1.5 seconds per 1/10th second step. See the explanation that follows. By default, this time is zero.

### Activating Outputs

The following illustration describes the output operating differences between the choice of active phase 1 Outputs: S0 or S0 and S1.

#### Active output phase 1 (S0)

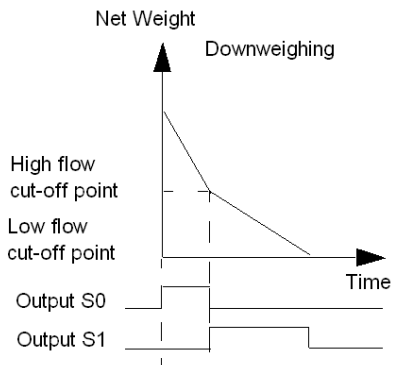
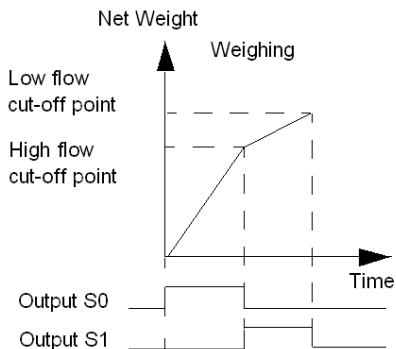

#### Active output phase 1 (S0 and S1)

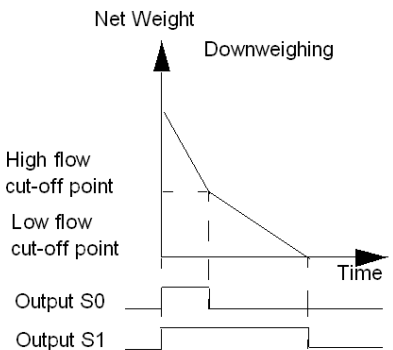
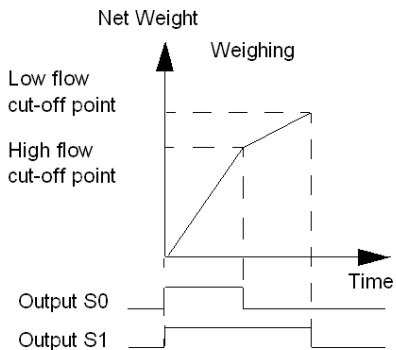

## Masking Time

The following illustration shows the role of the masking time, the aim of which is to mask the overshoot caused when the product has a drop in voltage.

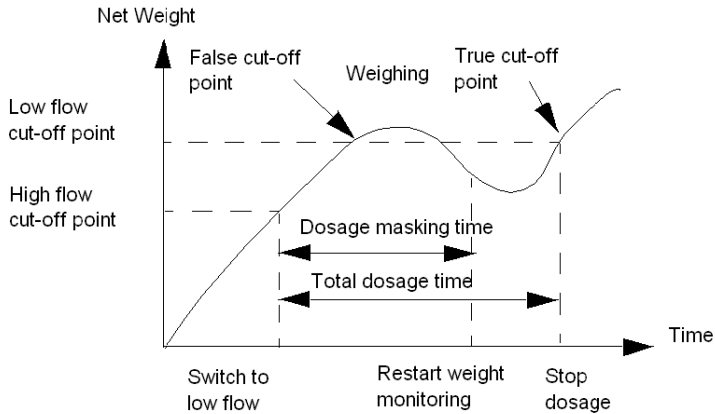

## Procedure

The following table shows the procedure for the threshold check.

Step	Action
1	Access the weighing module configuration screen.
2	If necessary check the <b>Active</b> box in the <b>Threshold check</b> field to activate this function.
3	Check the selection boxes corresponding to the detection direction ( <b>Weighing</b> or <b>Downweighing</b> ) and to the phase 1 active outputs ( <b>S0</b> or <b>S0 and S1</b> ).
4	Enter the <b>Low flow</b> and <b>High flow</b> in the <b>Breaking points</b> field.
5	Using the drop-down menu in the <b>Threshold check</b> field, select the <b>PD masking time</b> .
6	Confirm the modification with the command <b>Edit → Validate</b> .



---

# Chapter 7

## Weighing Module Language Objects

---

### Introduction

This section describes the language objects associated with the weighing module from the various IODDTs.

### What Is in This Chapter?

This chapter contains the following sections:

Section	Topic	Page
7.1	Weighing Application Programming Principles	66
7.2	Language Objects and IODDT	72
7.3	The IODDTs of the Weighing Module	82
7.4	Description of the Commands Conveyed by the Program	91
7.5	Modifying the Parameters by Program	101

# Section 7.1

## Weighing Application Programming Principles

---

### Introduction

This section describes the general principles of programming a weighing application.

### What Is in This Section?

This section contains the following topics:

Topic	Page
Weighing Application Programming Principles	67
Addressing Language Objects Associated with the Weighing Module	69
Description of the Main Objects Linked to the Weighing Function	70

## Weighing Application Programming Principles

### Introduction

Once it is configured, the weighing module is fitted with sensors and linked to a TSX XBT display. The TSX ISP Y101 can operate autonomously (without a program). These outputs may be controlled without the intervention of the PLC program.

Programming at the level of the PLC makes it possible to:

- make weighing information available in order to carry out other processes or to drive other control devices
- dynamically modify the weighing function parameters by means of explicit commands

For the exchange objects of the IODDT of types T\_WEIGHING\_ISPY101 and T\_WEIGHING\_ISPY101\_2, use them as follows:

- **Premium/Atrium:** T\_WEIGHING\_ISPY101
- **M580:** T\_WEIGHING\_ISPY101\_2

### Access to Measurements

The numerical values of the (GROSS or NET) weights and flow rate are stored in 2 double word input registers (%ID). They are completed by 1 measurement Status word (%W), 1 tare value double word (%ID) and 1 calibration memory double word (%ID) (offset from zero).

i.e. a variable IODDT\_VAR1 IODDT T\_WEIGHING\_ISPY101.

The table below lists the weighing numerical values transmitted by the weighing function.

Symbol	Register Address	Meaning of the Register
IODDT_VAR1.WEIGHT	%IDr.m.0.0	Weight value (GROSS or NET)
IODDT_VAR1.FLOW_RATE	%IDr.m.0.2	Flow
IODDT_VAR1.MEASURE_DATA	%IWm.m.0.4	Measurement state: stability, zero ...
IODDT_VAR1.TARE	<b>Premium/Atrium:</b> %IDr.m.0.5 <b>M580:</b> %IDr.m.0.6	Tare value
IODDT_VAR1.OFFSET_MEM_VAL	<b>Premium/Atrium:</b> %IDr.m.0.7 <b>M580:</b> %IDr.m.0.8	Recalibration memory (zero offset)

These data are returned automatically to the processing unit at the start of the task associated with the channel, whether the task is in Run or Stop mode. The data are directly accessible by the:

- application via an operator dialog (access to PLC memory image objects)
- terminal using the animation tables

### Dynamic Modification of the Parameters

The preset adjustment parameters may be modified automatically during the operation of the program with the explicit exchange instruction `WRITE_PARAM`.

**Example:** modification of the SO high flow and SI low flow cut-off-points

## Addressing Language Objects Associated with the Weighing Module

### Introduction

This page introduces addressing specifics linked to weighing modules.

### Illustration

Reminder of addressing principle:



### Specific Values

The table below gives the values that are specific to weighing module objects.

Element	Values	Comment
r	0 to 7	rack address
m	0 to 14	position of the module in the rack
c	0 or MOD	0 channel number. MOD: channel reserved for module management and parameters common to all channels
d	0 to 16 or ERR	ERR: indicates a detected module or channel error

## Description of the Main Objects Linked to the Weighing Function

### Illustration

The illustration presents the formation of the different functions executed by the module, and the associated language objects.

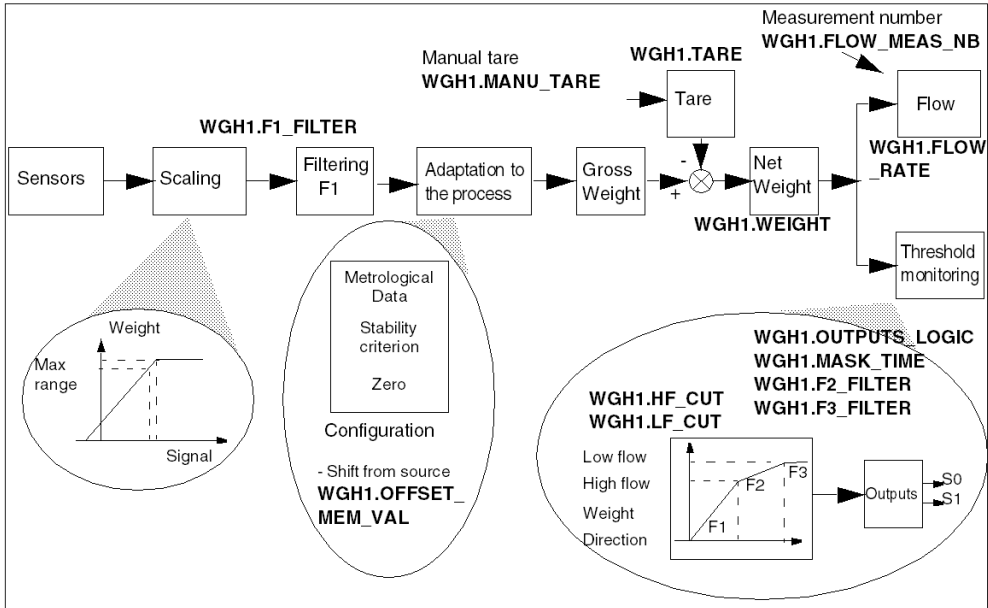

## Description

The following table describes the main language objects.

If the application is for a Premium/Atrium PLC, the IODDT exchange objects are of type  
T\_WEIGHTING\_ISPY101.

If the application is for an M580 PAC, the IODDT exchange objects are of type  
T\_WEIGHTING\_ISPY101\_2.

Symbol	Address	Type of Object to Exchange	Role
WGH1.WEIGHT	%IDr.m.0.0	Implicit	Weight value (gross or net)
WGH1.FLOW_RATE	%IDr.m.0.2	Implicit	Flow
WGH1.TARE	<b>Premium/Atrium:</b> %IDr.m.0.5 <b>M580:</b> %IDr.m.0.6	Implicit	Tare value
WGH1.OFFSET_MEM_VAL	<b>Premium/Atrium:</b> %IDr.m.0.7 <b>M580:</b> %IDr.m.0.8	Implicit	Recalibration memory (zero offset)
WGH1.F1_FILTER	%MWr.m.0.6	Explicit	F1 filter coefficient
WGH1.MANU_TARE	%MWr.m.c.0	Explicit	Manual tare
WGH1.HF_CUT	%MDr.m.0.8	Explicit	S0 high flow cut-off point (dosage)
WGH1.LF_CUT	%MDr.m.0.10	Explicit	S1 high flow cut-off point (dosage)
WGH1.OUTPUTS_LOGIC	%MWr.m.0.12	Explicit	Logic of outputs S0 and S1 (dosage)
WGH1.MASK_TIME	%MWr.m.0.13	Explicit	PD mask time
WGH1.FLOW_MEAS_NB	%MWr.m.0.14	Explicit	Number of measurements used to calculate flow rate
WGH1.F2_FILTER	%MWr.m.0.15	Explicit	F2 filter coefficient
WGH1.F3_FILTER	%MWr.m.0.16	Explicit	F3 filter coefficient

## Section 7.2

### Language Objects and IODDT

---

#### Introduction

This section describes the general features of the language objects and the IODDT of the weighing module.

#### What Is in This Section?

This section contains the following topics:

Topic	Page
Presentation of Language Objects Associated with the Weighing Function	73
Implicit Exchange Language Objects Associated with the Application-Specific Function	74
Explicit Exchange Language Objects Associated with the Application-Specific Function	75
Management of Exchanges and Reports with Explicit Objects	77

---

## Presentation of Language Objects Associated with the Weighing Function

### Introduction

The weighing module has various associated IODDTs.

The IODDTs are predefined by the manufacturer and contain output/input language objects belonging to the channel of an application-specific module.

The weighing function IODDTs are:

- T\_WEIGHING\_ISPY101: Use this IODDT for **Premium/Atrium** PLCs only.
- T\_WEIGHING\_ISPY101\_2: Use this IODDT for **Modicon M580** PLCs only.

**NOTE:** IODDT variables can be created in two different ways:

- Using the **I/O objects** (see *EcoStruxure™ Control Expert, Operating Modes*) tab
- Data Editor (see *EcoStruxure™ Control Expert, Operating Modes*)

Enhancement has been done to the TSXISPY101 module from version V2.2 (since CPU V2.6) to enable some advanced functions about the calibration by program. In particular the soft and forced calibration.

[Click here](#) to obtain information and examples (in English) on how to use the calibration by program with the IODDTs.

### Language Object Types

In each of the IODDTs there is a set of language objects enabling them to be controlled and check their operation.

There are two types of language objects:

- **implicit exchange objects**, which are automatically changed on each task cycle associated with the module
- **explicit exchange objects**, which are changed at the request of the application, using explicit exchange instructions

Implicit exchanges concern the inputs/outputs of the module: measuring results, information and commands.

Explicit exchanges are used to parameterize the module and to diagnose it.

## Implicit Exchange Language Objects Associated with the Application-Specific Function

### At a Glance

An integrated application-specific interface or the addition of a module automatically enhances the language objects application used to program this interface or module.

These objects correspond to the input/output images and software data of the module or integrated application-specific interface.

### Reminders

The module inputs (%I and %IW) are updated in the PLC memory at the start of the task, the PLC being in RUN or STOP mode.

The outputs (%Q and %QW) are updated at the end of the task, only when the PLC is in RUN mode.

**NOTE:** When the task occurs in STOP mode, either of the following are possible, depending on the configuration selected:

- outputs are set to fallback position (fallback mode)
- outputs are maintained at their last value (maintain mode)

### Figure

The following diagram shows the operating cycle of a PLC task (cyclical execution).

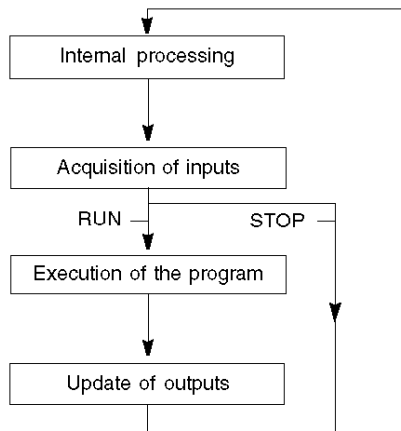

---

## Explicit Exchange Language Objects Associated with the Application-Specific Function

### Introduction

Explicit exchanges are performed at the user program's request using these instructions:

- READ\_STS (read status words)
- WRITE\_CMD (write command words)
- WRITE\_PARAM (write adjustment parameters)
- READ\_PARAM (read adjustment parameters)
- SAVE\_PARAM (save adjustment parameters)
- RESTORE\_PARAM (restore adjustment parameters)

For more details about instructions, refer to .

These exchanges apply to a set of %MW objects of the same type (status, commands or parameters) that belong to a channel.

These objects can:

- provide information about the module (for example, type of error detected in a channel)
- have command control of the module (for example, switch command)
- define the module's operating modes (save and restore adjustment parameters in the process of application)

**NOTE:** To avoid several simultaneous explicit exchanges for the same channel, it is necessary to test the value of the word EXCH\_STS (%MW<sub>r.m.c.0</sub>) of the IODDT associated to the channel before calling any EF addressing this channel.

**NOTE:** Explicit exchanges are not supported when X80 analog and digital I/O modules are configured through an eX80 adapter module (BMECRA31210) in a Quantum EIO configuration. You cannot set up a module's parameters from the PLC application during operation.

### General Principle for Using Explicit Instructions

The diagram below shows the different types of explicit exchanges that can be made between the application and module.

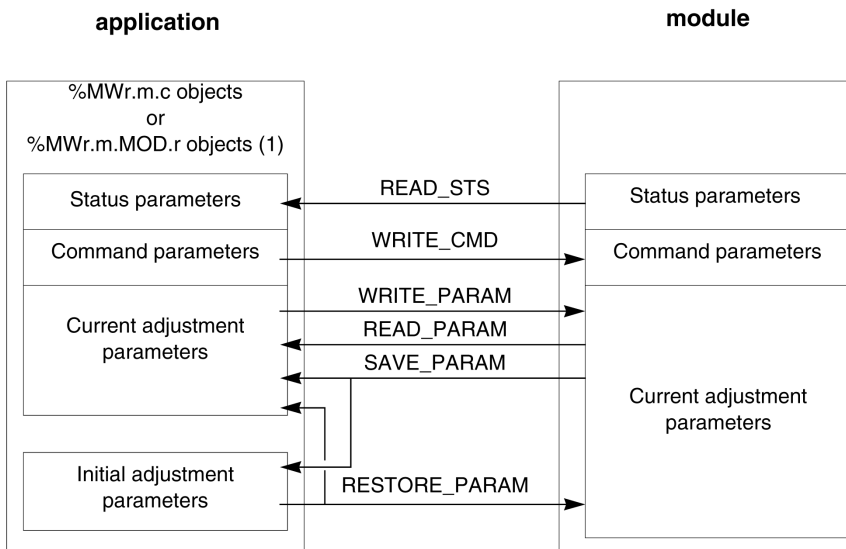

(1) Only with READ\_STS and WRITE\_CMD instructions.

### Managing Exchanges

During an explicit exchange, check performance to see that the data is only taken into account when the exchange has been correctly executed.

To do this, two types of information is available:

- information concerning the exchange in progress (*see page 80*)
- the exchange report (*see page 80*)

The following diagram describes the management principle for an exchange.

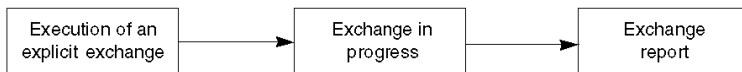

**NOTE:** In order to avoid several simultaneous explicit exchanges for the same channel, it is necessary to test the value of the word EXCH\_STS (%MWr.m.c.0) of the IODDT associated to the channel before calling any EF addressing this channel.

## Management of Exchanges and Reports with Explicit Objects

### At a Glance

When data is exchanged between the PLC memory and the module, the module may require several task cycles to acknowledge this information. IODDTs use two words to manage exchanges:

- EXCH\_STS (%MW<sub>r.m.c.0</sub>): exchange in progress
- EXCH\_RPT (%MW<sub>r.m.c.1</sub>): report

#### NOTE:

Depending on the localization of the module, the management of the explicit exchanges (%MW0.0.MOD.0.0 for example) will not be detected by the application:

- For in-rack modules, explicit exchanges are done immediately on the local PLC Bus and are finished before the end of the execution task. So, the READ\_STS, for example, is finished when the %MW0.0.mod.0.0 bit is checked by the application.
- For remote bus (Fipio for example), explicit exchanges are not synchronous with the execution task, so the detection is possible by the application.

### Illustration

The illustration below shows the different significant bits for managing exchanges:

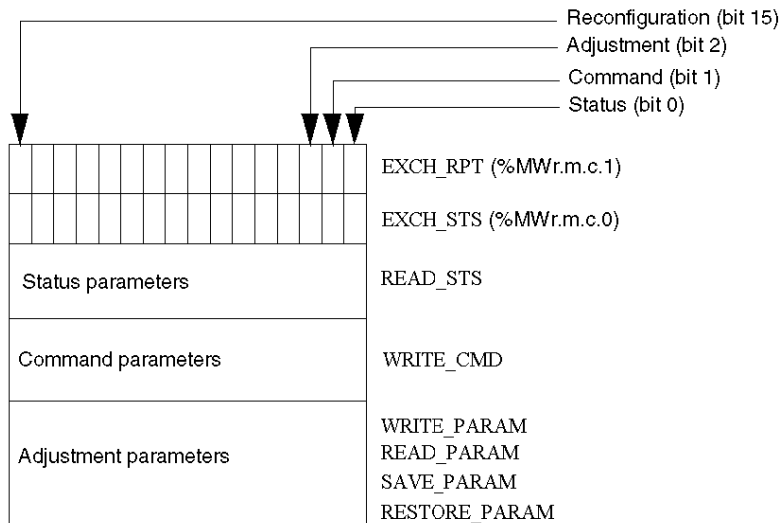

## Description of Significant Bits

Each bit of the words `EXCH_STS` (`%MWr.m.c.0`) and `EXCH_RPT` (`%MWr.m.c.1`) is associated with a type of parameter:

- Rank 0 bits are associated with the status parameters:
  - The `STS_IN_PROGR` bit (`%MWr.m.c.0.0`) indicates whether a read request for the status words is in progress.
  - The `STS_ERR` bit (`%MWr.m.c.1.0`) specifies whether a read request for the status words is accepted by the module channel.
- Rank 1 bits are associated with the command parameters:
  - The `CMD_IN_PROGR` bit (`%MWr.m.c.0.1`) indicates whether command parameters are being sent to the module channel.
  - The `CMD_ERR` bit (`%MWr.m.c.1.1`) specifies whether the command parameters are accepted by the module channel.
- Rank 2 bits are associated with the adjustment parameters:
  - The `ADJ_IN_PROGR` bit (`%MWr.m.c.0.2`) indicates whether the adjustment parameters are being exchanged with the module channel (via `WRITE_PARAM`, `READ_PARAM`, `SAVE_PARAM`, `RESTORE_PARAM`).
  - The `ADJ_ERR` bit (`%MWr.m.c.1.2`) specifies whether the adjustment parameters are accepted by the module. If the exchange is correctly executed, the bit is set to 0.
- Rank 15 bits indicate a reconfiguration on channel **c** of the module from the console (modification of the configuration parameters + cold start-up of the channel).
- The *r*, *m* and *c* bits indicates the following elements:
  - the **r** bit represents the rack number.
  - The **m** bit represents the position of the module in the rack.
  - The **c** bit represents the channel number in the module.

**NOTE:** **r** represents the rack number, **m** the position of the module in the rack, while **c** represents the channel number in the module.

**NOTE:** Exchange and report words also exist at module level `EXCH_STS` (`%MWr.m.MOD`) and `EXCH_RPT` (`%MWr.m.MOD.1`) as per IODDT type `T_GEN_MOD`.

**Example**

Phase 1: Sending data by using the `WRITE_PARAM` instruction

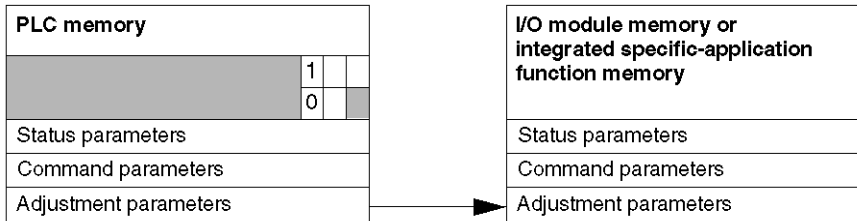

When the instruction is scanned by the PLC, the **Exchange in progress** bit is set to 1 in `%MWr.m.c`.

Phase 2: Analysis of the data by the I/O module and report.

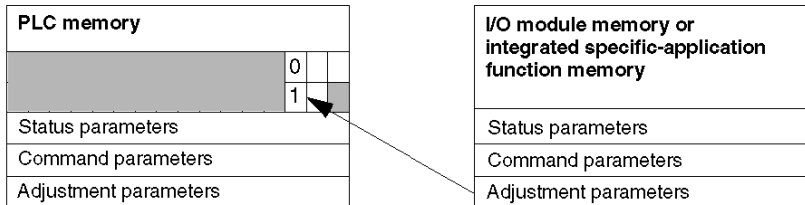

When the data is exchanged between the PLC memory and the module, acknowledgement by the module is managed by the `ADJ_ERR` bit (`%MWr.m.c.1.2`).

This bit makes the following reports:

- 0: correct exchange
- 1: incorrect exchange)

**NOTE:** There is no adjustment parameter at module level.

### Execution Indicators for an Explicit Exchange: EXCH\_STS

The table below shows the control bits of the explicit exchanges: EXCH\_STS (%MWr.m.c.0)

Standard Symbol	Type	Access	Meaning	Address
STS_IN_PROGR	BOOL	R	Reading of channel status words in progress	%MWr.m.c.0.0
CMD_IN_PROGR	BOOL	R	Command parameters exchange in progress	%MWr.m.c.0.1
ADJ_IN_PROGR	BOOL	R	Adjust parameters exchange in progress	%MWr.m.c.0.2
RECONF_IN_PROGR	BOOL	R	Reconfiguration of the module in progress	%MWr.m.c.0.15

**NOTE:** If the module is not present or is disconnected, explicit exchange objects (READ\_STS for example) are not sent to the module (STS\_IN\_PROG (%MWr.m.c.0.0) = 0), but the words are refreshed.

### Explicit Exchange Report: EXCH\_RPT

The table below shows the report bits: EXCH\_RPT (%MWr.m.c.1)

Standard Symbol	Type	Access	Meaning	Address
STS_ERR	BOOL	R	Error detected while reading channel status words (1 = detected error)	%MWr.m.c.1.0
CMD_ERR	BOOL	R	Error detected during a command parameter exchange (1 = detected error)	%MWr.m.c.1.1
ADJ_ERR	BOOL	R	Error detected during an adjust parameter exchange (1 = detected error)	%MWr.m.c.1.2
RECONF_ERR	BOOL	R	Error detected during reconfiguration of the channel (1 = detected error)	%MWr.m.c.1.15

## Counting Module Use

The following table describes the steps realized between a counting module and the system after a power-on.

Step	Action
1	Power on.
2	The system sends the configuration parameters.
3	The system sends the adjust parameters by WRITE_PARAM method. <b>Note:</b> When the operation is finished, the bit %MWr.m.c.0.2 switches to 0.

If, in the beginning of your application, you use a WRITE\_PARAM command, wait until the bit %MWr.m.c.0.2 switches to 0.

# Section 7.3

## The IODDTs of the Weighing Module

---

### Introduction

This section describes the various IODDTs and language objects associated with the weighing module.

### What Is in This Section?

This section contains the following topics:

Topic	Page
Details of the Implicit Exchange Objects of the IODDT of Types T_WEIGHING_ISPY101 and T_WEIGHING_ISPY101_2	83
Explicit Exchange Objects of the IODDT of Types T_WEIGHING_ISPY101 and T_WEIGHING_ISPY101_2	85
Explicit Exchange Objects of IODDT Types T_WEIGHING_ISPY101 and T_WEIGHING_ISPY101_2	87
Explicit Exchange Objects of the IODDT of Types T_WEIGHING_ISPY101 and T_WEIGHING_ISPY101_2	89
Details of the Language Objects of the T_GEN_MOD-Type IODDT	90

## Details of the Implicit Exchange Objects of the IODDT of Types T\_WEIGHING\_ISPY101 and T\_WEIGHING\_ISPY101\_2

### Introduction

This topic describes the implicit exchange objects of the IODDT of types T\_WEIGHING\_ISPY101 and T\_WEIGHING\_ISPY101\_2, which apply to the TSX ISP Y101 module.

- T\_WEIGHING\_ISPY101 is used with a **Premium/Atrium PLC** only.
- T\_WEIGHING\_ISPY101\_2 is used with a **Modicon M580 PLC** only.

Enhancement has been done to the TSXISP101 module from version V2.2 (since CPU V2.6) to enable some advanced functions about the calibration by program. In particular the soft and forced calibration.

[Click here](#) to obtain information and examples (in English) on how to use the calibration by program with the IODDTs.

### Error Bit %I.r.m.c.ERR

The table below shows the meaning of the error bit CH\_ERROR (%I.r.m.c.ERR):

Standard Symbol	Type	Access	Meaning	Address
CH_ERROR	BOOL	R	Error bit of the weighing channel	%I.r.m.c.ERR

### Word Objects

The table below shows the various implicit exchange word objects:

Standard Symbol	Type	Access	Meaning	Address
WEIGHT	DINT	R	<b>Weight value</b> (gross or net) By default, if no taring command has been executed, the weight value is expressed as a GROSS weight. It changes to NET weight as soon as the taring command is executed or a tare has been manually introduced. The measurement is expressed in legal format or high resolution according to the choice created at configuration.	%IDr.m.0.0
FLOW_RATE	DINT	R	<b>Flow</b> Example: %IDxy.0.2 = 450 000 means that, if the scale division is equal to $1.10^{-2}$ kg, a weight difference of 45 kg has been measured between n measurements (sampling every 20 ms). The n number of measurements is defined at configuration.	%IDr.m.0.2

Standard Symbol	Type	Access	Meaning	Address
TARE	DINT	R	<b>Tare value</b> This word allows the current tare value to be visualized in the same format as the weight. It is memorized by the module. It is reset to 0 at each calibration.	<b>T_WEIGHTING_ISPY101:</b> %IDr.m.0.5  <b>T_WEIGHTING_ISPY101_2:</b> %IDr.m.0.6
OFFSET_MEM_VAL	DINT	R	<b>Recalibration memory</b> (zero offset) This word allows the offset to be visualized currently in high resolution format. This value is memorized by the module. It is reset to 0 at each calibration.	<b>T_WEIGHTING_ISPY101:</b> %IDr.m.0.7  <b>T_WEIGHTING_ISPY101_2:</b> %IDr.m.0.8

### Measurement State Word Objects

The table below shows the various status word bits `MEASURE_DATA` (%IW.r.m.0.4):

Standard Symbol	Type	Access	Meaning	Address
Q0_OUT	BOOL	R	Image of output S0	%IW.r.m.0.4.0
Q1_OUT	BOOL	R	Image of output S1	%IW.r.m.0.4.1
UNDERLOAD	BOOL	R	Indicator that voltage is too low. The measurement is deviating. Check the field wiring and the accuracy of the sensor.	%IW.r.m.0.4.2
OVERLOAD	BOOL	R	Voltage too high on module input	%IW.r.m.0.4.3
SEALED_ON	BOOL	R	Sealed module	%IW.r.m.0.4.4
IN_PROGR	BOOL	R	Processing in progress (Taring, Reset, etc.)	%IW.r.m.0.4.5
CAL_IN_PROGR	BOOL	R	Calibration during processing	%IW.r.m.0.4.6
CMD_FLT	BOOL	R	Error detected during command	%IW.r.m.0.4.7
NET	BOOL	R	NET weight measurement	%IW.r.m.0.4.8
STABILITY	BOOL	R	Measurement instability This is set when the measurement is outside the stability range during the defined time. The extent of the stability range and the time are defined during configuration.	%IW.r.m.0.4.9
ZERO	BOOL	R	Zero indicator. This is set when the deviation from zero is no greater than +/- 1/4 of the scale division.	%IW.r.m.0.4.10
ZERO_TRACK	BOOL	R	Zero tracking indicator active	%IW.r.m.0.4.11
PREDEF_TARE	BOOL	R	Predefined or manual tare indicator (language element specific to module, accessible in read only). This is set when the tare is not the result of a taring command but rather an entry by the user.	%IW.r.m.0.4.12

## Explicit Exchange Objects of the IODDT of Types T\_WEIGHTING\_ISPY101 and T\_WEIGHTING\_ISPY101\_2

### Introduction

This topic describes the explicit exchange objects of the IODDT of types T\_WEIGHTING\_ISPY101 and T\_WEIGHTING\_ISPY101\_2, which apply to the TSX ISP Y101 module. These IODDTs group together the word objects, the bits of which have a particular meaning.

- T\_WEIGHTING\_ISPY101 is used with a **Premium/Atrium PLC** only.
- T\_WEIGHTING\_ISPY101\_2 is used with a **Modicon M580 PLC** only.

Example of declaration of a variable: IODDT\_VAR1 T\_WEIGHTING\_ISPY101.

### Notes

- Generally speaking the meaning of the bits is given for the state 1 of this bit. In specific cases each bit state is explained.
- Not all the bits are used.

### Managing Exchanges: EXCH\_STS

The following table describes the meaning of the exchange control bits of the channel EXCH\_STS (%MWr.m.0.0).

Standard Symbol	Type	Access	Meaning	Address
STS_IN_PROGR	BOOL	R	Exchange of the status parameters (STATUS) in progress	%MWr.m.0.0.0
CMD_IN_PROGR	BOOL	R	Command parameters exchange in progress	%MWr.m.0.0.1
ADJ_IN_PROGR	BOOL	R	Adjustment parameters exchange in progress	%MWr.m.0.0.2
RECONF_IN_PROGR	BOOL	R	Reconfiguring the module	%MWr.m.0.0.15

### Exchange Report: EXCH\_RPT

The following table describes the meaning of the report bits EXCH\_RPT (%MWr.m.0.1).

Standard Symbol	Type	Access	Meaning	Address
STS_ERR	BOOL	R	Exchange report of the status parameters (STATUS)	%MWr.m.0.1.0
CMD_ERR	BOOL	R	Exchange report of the command parameters	%MWr.m.0.1.1
ADJ_ERR	BOOL	R	Exchange report of the adjustment parameters	%MWr.m.0.1.2
RECONF_ERR	BOOL	R	Configuration mismatch	%MWr.m.0.1.15

### Operating State of the Channel: CH\_FLT

The following table describes the meaning of the bits of the status word CH\_FLT (%MWr.m.0.2), read is carried out by a READ\_STS (IODDT\_VAR1).

Standard Symbol	Type	Access	Meaning	Address
CAL_OVERLOAD_FLT	BOOL	R	External error: Overload or underload during calibration	%MWr.m.0.2.0
OVER_RANGE_FLT	BOOL	R	Range (2) overshoot or dynamics lower than 4.5mV at calibration	%MWr.m.0.2.1
SAT_FLT	BOOL	R	External error: saturation of the measurement circuit	%MWr.m.0.2.2
SEALED_FLT	BOOL	R	External error: sealed module, configuration refused	%MWr.m.0.2.3
INTERNAL_FLT	BOOL	R	Internal error: inoperable module	%MWr.m.0.2.4
CONF_FLT	BOOL	R	Configuration mismatch: the current module is not the one declared on configuration	%MWr.m.0.2.5
COM_FLT	BOOL	R	Detected communication error with the processor	%MWr.m.0.2.6
APPLI_FLT	BOOL	R	Detected application error	%MWr.m.0.2.7
PROTECT_FLT	BOOL	R	Protected module refuses the parameter because it influences the current value.	%MWr.m.c.2.8
NON_CAL_FLT	BOOL	R	Module not calibrated	%MWr.m.0.2.9
OVERLOAD_FLT	BOOL	R	Overload detected	%MWr.m.0.2.10
UNDERLOAD_FLT	BOOL	R	Underload detected	%MWr.m.0.2.11
TARE_MODE	BOOL	R	Taring mode	%MWr.m.0.2.12
ZERO_MODE	BOOL	R	Zero mode	%MWr.m.0.2.13
CAL_MODE	BOOL	R	Calibration mode	%MWr.m.0.2.14
FORCED_CAL_MODE	BOOL	R	Forced calibration mode	%MWr.m.0.2.15

## Explicit Exchange Objects of IODDT Types T\_WEIGHTING\_ISPY101 and T\_WEIGHTING\_ISPY101\_2

### Introduction

These word type objects allow commands to be sent to the weighing module by explicit exchange (WRITE\_CMD instruction):

- **Premium/Atrium:** %MWr.m.0.3, %MDr.m.0.4
- **M580:** %MWr.m.0.3, %MWr.m.0.4, and %MWr.m.0.5

This topic describes the explicit exchange objects of the IODDT of types T\_WEIGHTING\_ISPY101 and T\_WEIGHTING\_ISPY101\_2, which apply to the TSX ISP Y101 module. These IODDTs group together the word objects, the bits of which have a particular meaning.

- T\_WEIGHTING\_ISPY101: Use this IODDT with a Premium/Atrium PLC only.
- T\_WEIGHTING\_ISPY101\_2: Use this IODDT with an M580 PLC only.

### Word Objects

The following table describes the meaning of explicit command parameters %MWCmd used with WRITE\_CMD explicit exchange.

Standard Symbol	Type	Access	Meaning	Address
CMD_TYPE	INT	R/W	Command type	%MWr.m.0.3
STD_LOAD <sup>1</sup>	DINT	R/W	Standard load weight for the calibration command	%MDr.m.0.4
STD_LOAD_L <sup>2</sup>	INT	R/W	Standard load weight for the calibration command (least significant word)	%MWr.m.0.4
STD_LOAD_H <sup>2</sup>	INT	R/W	Standard load weight for the calibration command (most significant word)	%MWr.m.0.5
<sup>1</sup> Premium/Atrium only				
<sup>2</sup> M580 only				

**NOTE:** The standard load weight **S** is a DINT. (The **S** value is typically between 10 and 400,000.) To perform a calibration by program ([see page 124](#)), the least significant word of the standard load weight value **S** is copied into %MWr.m.0.4, and the most significant word of the standard load weight value **S** is copied into %MWr.m.0.5. This takes place before executing WRITE\_CMD while setting the calibration order of the channel using the standard load weight.

**Example:** The standard load weight for calibration **S** can be copied into the %MWr.m.0.4 and %MWr.m.0.5 words as follows:

```
DINT_AS_WORD (S, LowWord, HighWord);
%MWr.m.0.4:=WORD_TO_INT(LowWord);
%MWr.m.0.5:=WORD_TO_INT(HighWord);
```

**Managing Exchanges: CMD\_TYPE**

The following table describes the meaning of the word bits `CMD_TYPE` (%MWr.m.0.3).

Standard Symbol	Type	Access	Meaning	Address
MOD_CAL_SAVE_CMD	BOOL	R/W	Save calibration coefficients in module	%MWr.m.0.3.0
ZERO_LOAD_CAL_CMD	BOOL	R/W	Zero Load calibration	%MWr.m.0.3.1
STD_LOAD_CAL_CMD	BOOL	R/W	Calibration Weight Calibration (normal condition)	%MWr.m.0.3.2
CANCEL_CMD	BOOL	R/W	Cancellation of command (calibration, setting to zero, taring)	%MWr.m.0.3.3
TARE_CMD	BOOL	R/W	Taring order	%MWr.m.0.3.4
ZERO_CMD	BOOL	R/W	Reset order	%MWr.m.0.3.5
GROSS_CMD	BOOL	R/W	Return to GROSS weight order	%MWr.m.0.3.6
MANU_TARE_DISP_CMD	BOOL	R/W	3 second display of manual tare	%MWr.m.0.3.7
TH_EN_CMD	BOOL	R/W	Enable thresholds	%MWr.m.0.3.8
TH_DIS_CMD	BOOL	R/W	Disable thresholds	%MWr.m.0.3.9
FORCED_CAL_CMD	BOOL	R/W	Forced calibration (CPU -> module)	%MWr.m.0.3.10
CPU_CAL_SAVE_CMD	BOOL	R/W	Save calibration coefficients in processor	%MWr.m.0.3.11
DG_CAL_CMD	BOOL	R/W	Standard load calibrated at < 70 % of maximum weight	%MWr.m.0.3.12

## Explicit Exchange Objects of the IODDT of Types T\_WEIGHTING\_ISPY101 and T\_WEIGHTING\_ISPY101\_2

### Introduction

This topic describes the explicit exchange objects of the IODDT of types T\_WEIGHTING\_ISPY101 and T\_WEIGHTING\_ISPY101\_2, which apply to the TSX ISP Y101 module. It groups together word objects.

- T\_WEIGHTING\_ISPY101: Use this IODDT with a Premium/Atrium PLC only.
- T\_WEIGHTING\_ISPY101\_2: Use this IODDT with a M580 PLC only.

Example of declaration of a variable: IODDT\_VAR1 of type T\_WEIGHTING\_ISPY101.

### Word Objects

The following table describes the meaning of the words. The requests used are those associated with the parameters (READ\_PARAM, WRITE\_PARAM, SAVE\_PARAM, RESTORE\_PARAM).

Standard Symbol	Type	Access	Meaning	Address
F1_FILTER	INT	R/W	F1 filter coefficient	%MWr.m.0.6
MANU_TARE	INT	R/W	Manual tare value	%MWr.m.0.7
HF_CUT	DINT	R/W	S0 high flow cut-off point (dosage)	%MDr.m.0.8
LF_CUT	DINT	R/W	S1 high flow cut-off point (dosage)	%MDr.m.0.10

### Output Logic

The following table describes the meaning of the word bits OUTPUTS\_LOGIC (%MWr.m.0.12). The requests used are those associated with the parameters (READ\_PARAM, WRITE\_PARAM, SAVE\_PARAM, RESTORE\_PARAM).

Standard Symbol	Type	Access	Meaning	Address
WEIGH_UNWEIGH	BOOL	R/W	Low Flow mask time	%MWr.m.0.12.0
Q0_OR_QOQ1	BOOL	R/W	Number of measurements used to calculate flow rate	%MWr.m.0.12.1

### Word Objects

The following table describes the meaning of the words. The requests used are those associated with the parameters (READ\_PARAM, WRITE\_PARAM, SAVE\_PARAM, RESTORE\_PARAM).

Standard Symbol	Type	Access	Meaning	Address
MASK_TIME	INT	R/W	Low Flow mask time	%MWr.m.0.13
FLOW_MEAS_NB	INT	R/W	Number of measurements used to calculate flow rate	%MWr.m.0.14
F2_FILTER	INT	R/W	F2 filter coefficient	%MWr.m.0.15
F3_FILTER	INT	R/W	F3 filter coefficient	%MWr.m.0.16

## Details of the Language Objects of the T\_GEN\_MOD-Type IODDT

### Introduction

Modules of Premium PLCs have an associated IODDT of type T\_GEN\_MOD.

### Observations

- In general, the meaning of the bits is given for bit status 1. In specific cases, an explanation is given for each status of the bit.
- Not all bits are used.

### List of Objects

The table below presents the objects of the IODDT:

Standard symbol	Type	Access	Meaning	Address
MOD_ERROR	BOOL	R	Module error bit	%I.r.m.MOD.ERR
EXCH_STS	INT	R	Module exchange control word	%MWr.m.MOD.0
STS_IN_PROGR	BOOL	R	Reading of status words of the module in progress	%MWr.m.MOD.0.0
EXCH_RPT	INT	R	Exchange report word	%MWr.m.MOD.1
STS_ERR	BOOL	R	Error detected while reading module status words	%MWr.m.MOD.1.0
MOD_FLT	INT	R	Internal error word of the module	%MWr.m.MOD.2
MOD_FAIL	BOOL	R	Internal error, inoperable module	%MWr.m.MOD.2.0
CH_FLT	BOOL	R	Channel error detected	%MWr.m.MOD.2.1
BLK	BOOL	R	Terminal block error	%MWr.m.MOD.2.2
CONF_FLT	BOOL	R	Hardware or software configuration mismatch	%MWr.m.MOD.2.5
NO_MOD	BOOL	R	Module missing or inoperative	%MWr.m.MOD.2.6
EXT_MOD_FLT	BOOL	R	Internal error word of the module (Fipio extension only)	%MWr.m.MOD.2.7
MOD_FAIL_EXT	BOOL	R	Module is unserviceable (Fipio extension only)	%MWr.m.MOD.2.8
CH_FLT_EXT	BOOL	R	Channel error detected (Fipio extension only)	%MWr.m.MOD.2.9
BLK_EXT	BOOL	R	Terminal block error detected (Fipio extension only)	%MWr.m.MOD.2.10
CONF_FLT_EXT	BOOL	R	Hardware or software configuration mismatch (Fipio extension only)	%MWr.m.MOD.2.13
NO_MOD_EXT	BOOL	R	Module missing or inoperative (Fipio extension only)	%MWr.m.MOD.2.14

---

## Section 7.4

### Description of the Commands Conveyed by the Program

---

#### Introduction

This section describes the different commands that can be executed by program.

#### What Is in This Section?

This section contains the following topics:

Topic	Page
Sending Commands to the Weighing Module by Program	92
How to Perform a Tare Mode by Program	93
How to Reset the Value of the Weight to Zero by Program	95
How to Return to Gross Weight Measurement via the Program	97
How to Display the Manual Tare via the Program	98
How to Enable or Disable Thresholds by Program	99

## Sending Commands to the Weighing Module by Program

### Introduction

Commands are sent to the module using the `WRITE_CMD` instruction with the following syntax:

```
WRITE_CMD (%Chr.m.0)
```

This instruction sends the order to the module and awaits its acknowledgement. This wait may require several task cycles.

**NOTE:** The module only interprets one command at a time. If a command is requested while the previous command is being processed, the new command is refused. Only one bit will be at 1 in the command word.

### Monitoring parameter recognition

As the module may require several task cycles to recognize commands, two memory words are standardized to control the `%MWr.m.0.0` and `%MWr.m.0.1` exchanges

The first word `%MWr.m.0.0` indicates a current exchange.

The second word `%MWr.m.0.1` gives the exchange report.

The following table describes the objects used for controlling the sending of commands to the module.

Address	Meaning (for the bit at state 1)
<code>%MWr.m.0.0.1</code>	Indicates that the command has been sent to the module.
<code>%MWr.m.0.1.1</code>	Shows if the command is accepted by the module.
<code>%MWr.m.0.2.7</code>	Signals that a command or parameter has been refused.

## How to Perform a Tare Mode by Program

### Introduction

This function involves bringing the value of the measured net weight to zero when a load, or tare, is placed on the load holder.

It therefore supports movement of the measurement with an offset value in order to make it conform to the user's expected value.

When no tare mode operation has been carried out, the net weight is the same as the gross weight.

#### NOTE:

- When changing configuration, tares are deleted. Any tare mode command cancels tares entered in manual mode and resets the *manual* tare indicator to zero.
- Similarly, a return to gross weight order allows you to delete tare modes. It does not need any acceptance condition.

### Execution Conditions for the Tare Mode

The acceptance conditions for performing the tare mode command are the following:

- The measurement is stable.
- The measurement is below the maximum range.
- The measurement is strictly positive.

### Procedure

The following table describes the procedure for executing a tare mode operation.

Step	Action	Behavior of the Module
1	Input the <code>WRITE_CMD</code> instruction while positioning the tare mode order ( <code>%MWr.m.0.3.4 = 1</code> ).	-
2	Confirm the execution, with the application in RUN mode.	The module switches to tare mode and sends the <code>%IWr.m.0.4.5 = 1 Processing _ in_ progress</code> report. Acquires the tare. <b>Note:</b> The value of the weight is measured and stored in the associated <code>%IDr.m.0.5</code> (for <b>Premium/Atrium</b> ) and <code>%IDr.m.0.6</code> (for <b>M580</b> ). It will be deducted from further gross weight measurements to determine the net weight. End of acquisition: <code>Processing_in_progress = 0</code>
3	Monitor the command's smooth execution: State of <code>Processing_in_progress: %IWr.m.0.4.5</code>	The module stays in the <code>Processing_in_progress</code> state for as long as the acceptance conditions are not met or until it receives an order to cancel the command.

## Summary of the Data Used

The following table describes the data used for a tare mode.

Type	Role	Associated Data
Command	tare mode order	%MWr.m.0.3.4
Display	tare value	<b>Premium/Atrium:</b> %IDr.m.0.5 <b>M580:</b> %IDr.m.0.6
	tare mode in progress	%IW2r.m.0.4.5

## Example

The following example in instruction list language describes a tare mode order being sent to the weighing module in slot 2, rack 0.

```
LD TRUE
S  %MW 2.0.3.4
[WRITE_CMD  (%CH2.0) ]
```

Executing the program involves:

Phase	Description
1	Sending the command.
2	Setting the %MW2.0.0.1 bit to 1, showing that the command is being sent.
3	This bit remains at 1 until the module sends a report. The bit then goes back to 0. The exchange report bit is then relevant.
4	The exchange report bit %MW2.0.1.1 rises to 1 if an error is detected during the exchange. The 0 value shows that the command has been accepted by the module.

**NOTE:** %IW2.0.4.5 stays at 1 (processing in progress) for as long as the acceptance conditions are not met (waiting for measurement stability, for example).

The status channel's application error bit is at 1 (module executing command). The order can be cancelled by sending the *cancel command in progress* command.

## How to Reset the Value of the Weight to Zero by Program

### Introduction

This function consists in moving the measured weight value to zero. The zero indicator is then put into position.

It is controlled by the command bit **Set to Zero**. The correction carried out on the measurement is stored in the word %IDr.m.0.7 (for **Premium/Atrium**) and %IDr.m.0.8 (**M580**), in a high resolution format. It can be saved by the application. This parameter is reset to zero on each calibration.

**NOTE:** On changing configuration, any setting to zero is deleted.

### Conditions for Carrying Out Zero Setting

The acceptance conditions for performing the zero setting command are the following:

- The measurement is in gross weight.
- The measurement is stable.
- The measurement is included in the preset zero range extent.

### Procedure

The following table describes the procedure for executing a tare mode operation.

Step	Action	Behavior of the Module
1	Input the <code>WRITE_CMD</code> while setting the order <b>Set to zero</b> (%MWr.m.0.3.5 = 1).	-
2	Confirm the execution, with the application in RUN mode.	The module switches to <b>set to zero</b> and sends the <b>Processing_in_progress</b> report %IWm.m.0.4.5 = 1. The module proceeds to the acquisition of the measurement and memorizes the new value in the recalibration memory %IDr.m.0.7 ( <b>Premium/Atrium</b> ) and %IDr.m.0.8 ( <b>M580</b> ). <b>Processing_in_progrees</b> = 0 signifies the end of the procedure.
3	Monitor the command's smooth execution: State of <b>Processing_in_progress</b> : %IWm.m.0.4.5	The module stays in the <b>Processing_in_progress</b> state for as long as the acceptance conditions are not met or until it receives an order to cancel the command.

## Summary of the Data Used

The following table describes the data used for resetting to zero.

Type	Role	Associated Data
command	reset order	%MWr.m.0.3.5
display	recalibration memory	<b>Premium/Atrium:</b> %IDr.m.0.7 <b>M580:</b> %IDr.m.0.8
exchange	processing in progress	%IW2.m.0.4.5

## Example

The following example in instruction list language describes a **Reset order** being sent to the weighing module in slot 2, rack 0.

```
LD TRUE
S  %MW 2.0.30.5
[WRITE_CMD    (%CH2.0) ]
```

Executing this order involves:

Phase	Description
1	Sending the command.
2	Setting the %MW2.0.0.1 bit to 1, showing that the command is being sent.
3	This bit remains at 1 until the module sends a report. The bit then goes back to 0. The exchange report bit is then relevant.
4	The exchange report bit %MW2.0.1.1 rises to 1 if an error is detected during the exchange. The 0 value shows that the command has been accepted by the module.

**NOTE:** %IW2.0.4.5 stays at 1 (processing in progress) for as long as the acceptance conditions are not met (waiting for measurement stability, for example).

The status channel's application error bit is at 1 (module executing command).

The order can be cancelled by sending the **cancel command in progress** command.

## How to Return to Gross Weight Measurement via the Program

### Introduction

This function cancels the tare value so that the current weight value is in gross weight.

The current weight is stored in the word %IDr.m..0.0, in the format set in configuration.

### Execution Conditions for the Tare Mode

This command does not require any particular execution conditions.

### Procedure

The following table describes the procedure for executing a return to measurement in gross weight.

Step	Action	Behavior of the Module
1	Input the <code>WRITE_CMD</code> while programming the tare mode order (%MWr.m.0.3.6 = 1).	-
2	Confirm the execution, with the application in RUN.	The module switches to "return to gross weight" mode. The module then sets the tare to zero. The NET = 0 (%lwr.m..0.4.8=0) flag shows the end of the procedure.
3	Check that the command has been performed correctly: State of the NET flag: %lWr.m.0.4.8	-

### Summary of the Data Used

The following table provides the data used for resetting to zero.

Type	Role	Associated Data
Command	Return to gross weight order	%MWr.m.0.3.6
Display	Measured weight	%IDr.m.0.0
	Value of the Tare in progress	<b>Premium/Atrium:</b> %IDr.m.0.5 <b>M580:</b> %IDr.m.0.6
Exchange	Processing in progress	%lWr.m.0.4.5
	Gross weight	%lWr.m.0.4.8 = 0

## How to Display the Manual Tare via the Program

### Introduction

This function supports display of the manual tare on the display panel for 3 seconds.

### Execution Conditions for the Tare Mode

For this command, confirm that a manual tare has been configured.

### Procedure

The following table describes the procedure for displaying the manual tare.

Step	Action	Behavior of the Module
1	Input <code>WRITE_CMD</code> while positioning the display order ( <code>%MWr.m.0.3.7 = 1</code> ).	-
2	Confirm the execution, with the application in RUN mode.	The module manages its data normally. The values displayed on the <b>TSX XBT N410</b> display panel show the manual tare value.
3	After the 3 second delay, the display panel reverts to its current values.	-

### Summary of the Data Used

The following table below provides the data used for resetting to zero.

Type	Role	Associated Data
Command	Tare display order	<code>%MWr.m.0.3.7</code>
Display	Manual tare	The data on the display panel show the manual tare.

## How to Enable or Disable Thresholds by Program

### Introduction

These functions are primarily used to coordinate the output command in relation to the processor-managed mechanism.

Confirm that you have enabled the threshold check option in the configuration screen.

### Operating Principle

Action on outputs is performed from the command **Enabling of thresholds**. Once this command has been executed, the threshold check cycle starts.

A disable command is used to stop the threshold check cycle in progress and authorize a new threshold enabling command.

If need be, this command will also reset outputs S0 and S1 to 0.

### Enabling Procedure

The following table describes the procedure for validating thresholds.

Step	Action	Behavior of the Module
1	Make the necessary changes to the threshold values, output logic and mask time.	-
2	Set the threshold enabling order (%MWr.m.0.3.8 = 1).	-
3	Launch enable thresholds using the WRITE_CMD instruction.	The module interprets the request and sets the S0 and S1 outputs so that they update the image bits to reflect current positions of S0 and S1: <ul style="list-style-type: none"> <li>● %IW.r.m.0.4.0 current position of S0.</li> <li>● %IW.r.m.0.4.1 current position of S1.</li> </ul>

### Disabling Procedure

The following table describes the procedure for disabling thresholds.

Step	Action	Behavior of the module
1	Set the disable thresholds (%MWr.m.0.3.9 = 1).	-
2	Launch threshold disabling using the WRITE_CMD instruction.	The module sets outputs to idle and image bits to 0.

**Summary of the Data Used**

The following table provides the data used for enabling and disabling thresholds.

Type	Role	Associated Data
Command	Threshold enabling order	%MWr.m.0.3.8
	Threshold disabling order	%MWr.m.0.3.9
Display	Current flow	%IDr.m.0.2
	High flow threshold	%MDr.m.0.8
	Low flow threshold	%MDr.m.0.10
	Output logic	%MWr.m.0.12
	LF mask time	%MWr.m.0.13
	S0 current position	%IWr.m.0.4.0
	S1 current position	%IWr.m.0.4.1

---

## Section 7.5

### Modifying the Parameters by Program

---

#### Introduction

This section describes how to dynamically modify the application's parameters by program.

#### What Is in This Section?

This section contains the following topics:

Topic	Page
Modifying the Parameters by Program	102
Instructions Used for Adjustments	104
Description of Parameters Adjustable by Program	106
Reading Configuration Parameters	107

## Modifying the Parameters by Program

### Principle

You can command the modification of certain parameters by program, in order to automatically adapt the measurements to the processing applications.

**Example:** Modifying the tare value by program if several types of product are to be weighed with different packagings.

### List of Adjustable Parameters

The following parameters may be modified by program:

Adjustable Parameters	Corresponding Data
F1 filter coefficient	%MWr.m.0.6
"Manual" tare value	%MWr.m.0.7
Cut-off points (thresholds)	%MDr.m.0.8 and %MDr.m.0.10
Logic of S0 and S1 outputs	%MWr.m.0.12
LF mask time	%MWr.m.0.13
Number of measurements used to calculate flow rate	%MWr.m.0.14
F2 filter coefficient	%MWr.m.0.15
F3 filter coefficient	%MWr.m.0.16

### Possible Actions

You can:

- modify an adjustment parameter by program
- send adjustment parameters to the module
- control the module's parameter recognition
- read the adjustment parameter value in the module and thereby update the PLC memory
- save the adjustment parameters
- restore the value of saved parameters to the PLC memory

## Instructions Used

The instructions used to do these operations are as follows:

Instruction	Function Carried Out
WRITE_PARAM (%CH r.m.0)	Send the parameter contents of the previous table to the weighing module.
READ_PARAM (%CH r.m.0)	Reads the adjustment parameters in the module and updates the above table.
SAVE_PARAM (%CH r.m.0)	Saves the adjustment parameter values in the memory zone of the processor. These parameter values will be the ones used when the PLC is started from cold.
RESTORE_PARAM (%CH r.m.0)	Allows the adjustment parameters to be reloaded with the values entered at module configuration or at the last SAVE_PARAM.

The module can process several adjustments simultaneously.

## Instructions Used for Adjustments

### Introduction

To be able to carry out adjustment operations, you need access to the module's own data. Access is gained using the following instructions.

### Sending Adjustment Parameters to the Module

Parameters are sent from the module channel using the `WRITE_PARAM` instruction, with the following syntax:

```
WRITE_PARAM (%CH r.m.0)
```

This instruction sends the contents of the parameters to the module and waits for its acknowledgement. This may necessitate several task cycles.

### Monitoring Parameter Recognition

As the module can take several task cycles to acknowledge values, two memory words are used to monitor the exchanges: `%MWr.m.0.0` and `%MWr.m.0.1`

- The first word `%MWr.m.0.0` shows that there is an exchange in progress.
- The second word `%MWr.m.0.1` gives the exchange report.
- Rank 2 bits are associated with the adjustment parameters:
  - The `%MWr.m.0.0.2` bit shows that the adjustment parameters are sent to the module.
  - The `%MWr.m.0.1.2` bit specifies whether the adjustment parameters are accepted by the module.

### Example

Writing the module's parameters in slot 2 of rack 0:

```
WRITE_PARAM (%CH2.0) involves:
```

- Sending the adjustment parameters.
- Setting the `%MW2.0.0.2` bit to 1, showing that the adjustment parameters are being sent. This bit remains at 1 until the module sends a report. The bit then goes back to 0. The exchange report bit is then relevant.
- The `%MW2.0.1.2` exchange report bit is set at 1 if an error is detected during the exchange. The 0 value shows that the data has been accepted by the module.

### Reading the Adjustment Parameters

The `READ_PARAM` instruction is used to read the module's adjustment parameters and to update the PLC's memory. It is particularly useful after a `WRITE_PARAM` that the module has not accepted. Reading the adjustment parameters can take several task cycles.

The adjustment parameters are read from the module's channel using the `READ_PARAM` instruction, with the following syntax:

```
READ_PARAM (%CH r.m.0)
```

### Saving the Adjustment Parameters

The `SAVE_PARAM` instruction allows you to copy the current values of the module's adjustment parameters in the backup zone defined in the processor memory. The backup zone is not accessible from the language.

This instruction can take several task cycles to be executed. The module's adjustment parameters are saved using the `SAVE_PARAM` instruction, with the following syntax:

```
SAVE_PARAM (%CH r.m.0)
```

### Restoring the Saved Adjustment Parameters

The `RESTORE_PARAM` instruction supports restoring of the saved adjustment parameter values in the processor's memory and in the module.

The adjustment parameters are restored from the module using the `RESTORE_PARAM` instruction, with the following syntax:

```
RESTORE_PARAM (%CH r.m.0)
```

## Description of Parameters Adjustable by Program

### Description

The following table describes the parameters that can be adjusted by program, using the WRITE\_PARAM instruction.

Word	Role	Description
%MWr.m.0.6 %MWr.m.0.15 %MWr.m.0.16	Filter Coefficients	The admissible filter coefficient values are between 0 and 19.
%MWr.m.0.7	"Manual" tare value	The admissible "manual" tare values are between 0 and 65535. They cannot exceed the maximum range.
%MD r.m.0.8 %MD r.m.0.10	Cut-off points (thresholds)	S0 high flow cut-off point. S1 low flow cut-off point. The threshold values allowed lie between 0 and the maximum range in high resolution format. If a threshold check has not been defined at configuration, no detection processing is done. The value of these threshold is zero by default. <b>Note:</b> <ul style="list-style-type: none"> <li>● when weighing: <math>GD &lt; MW &lt; \text{Maximum weight}</math></li> <li>● in downweighing: <math>MW &lt; GD &lt; \text{Maximum weight}</math></li> </ul> The module carries out a consistency check of the threshold values. If this logic is not respected, the thresholds will be refused.
%MWr.m.0.12	Output logic	<ul style="list-style-type: none"> <li>● %MWr.m.0.12.0:               <ul style="list-style-type: none"> <li>○ 0: Weighing</li> <li>○ 1: Downweighing</li> </ul> </li> <li>● %MWr.m.0.12.1:               <ul style="list-style-type: none"> <li>○ 0: S0 then S1</li> <li>○ 1: S0 then S1 then S1</li> </ul> </li> </ul>
%MWr.m.0.13	PD mask time	The admissible values are between 0 and 15 per 1/10 second step (0 = 0 s, 1 = 0.1 s, 2 = 0.2 s, ...).
%MWr.m.0.14	Number of measurements for flow	Admissible values are values 2, 4, 8, 16, 32 or 64.

## Reading Configuration Parameters

### Introduction

The set of parameters entered during the configuration of the module is accessible by program in read only.

These parameters are coded in 3 words of the %KW constant area.

### Coding of the Maximum Weight

The maximum weight reading, configured for the measuring channel, may be accessed with the word %KWr.m.0.0.

### Coding the Measurement Unit

Reading the unit and the scale division, configured for the measuring channel, is accessible with the word %KWr.m.0.1.

The measurement unit is coded on 3 bits of the least significant byte.

%KWr.m.0.1: Least significant byte

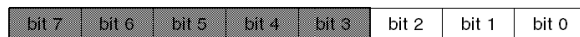

The following table describes the coding of the measurement unit.

Bits 0 to 2	Corresponding Unit	Role
0	g	gram
1	kg	kilogram
2	t	tonne (metric)
3	lb	pound (=453g)
4	oz	once (=28.35g)
5	<none>	no unit

### Scale Division Coding

The reading of the unit and the scale division configured for the measuring channel, is accessible with the word %KW<sub>r</sub>.m.0.1.

**NOTE:** The scale division is defined in the same unit as that of the measurement.

The measurement unit is coded on 5 bits of the most significant byte.

%KW<sub>r</sub>.m.0.1 of the most significant byte

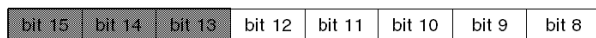

The following table describes the coding of the scale division.

Bits 8 to 12	Scale Division Value	Bits 8 to 12	Scale Division Value
0	0.001	11	5
1	0.002	12	10
2	0.005	13	20
3	0.01	14	50
4	0.02	15	100
5	0.05	16	200
6	0.1	17	500
7	0.2	18	1000
8	0.5	19	2000
9	1	20	5000
10	2		

### Coding of the Stability (of zero, thresholds, outputs, and format)

The reading of the extent of range and the stability time and the extent of range from zero and the activity of zero tracking, of the overload threshold, the utilization of the outputs and the format of the weight values, configured for the channel measurement are accessible with the memory word %KWr.m.0.2.

Coding of the word %KWr.m.0.2.

%KWr.m.0.2 : Least significant byte

bit 7	bit 6	bit 5	bit 4	bit 3	bit 2	bit 1	bit 0
Stability time				Extent of stability			

%KWr.m.0.2 of the most significant byte

bit 15	bit 14	bit 13	bit 12	bit 11	bit 10	bit 9	bit 8
Format	Outputs	Zero Tracking	Manual tare.	Extent. Zero	Supply sensor	Overload	

The following table describes the coding of the extent of stability (bits 0 to 2).

Value Read	Equivalence in 1/4 of the Scale Division
0	2
1	3
2	4
3	6
4	8

The following table describes the coding of the stability time (bits 4 to 5).

Value Read	Equivalence in Seconds
0	0.4
1	0.5
2	0.7
3	1

The following table describes the coding of the overload (bits 8 to 9).

Value Read	Type of Overload Selected
0	Maximum weight + 9 scale divisions
1	Maximum weight + 2% of the maximum weight
2	Maximum weight +5% of the maximum weight

The following table describes the coding of the other parameters. These parameters are each coded on one bit of the word %KWr.m.0.2.

Bit Number	Parameter	Bit at 0	Bit at 1
11	Recalibration range	+/-2% of the maximum weight	+/-5% of the maximum weight
12	Tare predefined	No predetermined tare	Tare predefined
13	Activity of the zero tracker	Inactive	Active
14	Utilization of the outputs	Not used	Used
15	Format	Legal (physical unit with fixed point)	High resolution ( hundredth of a fixed point physical unit)

---

# Chapter 8

## Debugging the Weighing Function

---

### Introduction

This chapter introduces the debugging screen and describes the functions available for debugging the application.

### What Is in This Chapter?

This chapter contains the following topics:

Topic	Page
Introduction to the Debug Function of the Weighing Module	112
Description of the Weighing Application Function Debug Screen	113
Description of the Module Zone of the Debug Screen	115
Description of the Display Zone of the Debug Screen	116
Description of the Parameter Setting Zone	117

## Introduction to the Debug Function of the Weighing Module

### Introduction

The Debug function makes it possible for the weighing module of the application to display the parameters of each of its channels (channel status etc.), to access the diagnostic and the adjustment of the selected channel.

The function also gives access to the module diagnostics so that you can detect and adjust errors and parameter mismatches.

**NOTE:** This function is only accessible in online mode.

## Description of the Weighing Application Function Debug Screen

### Introduction

The debug screen (see *EcoStruxure™ Control Expert, Operating Modes*) can be used to display weighing information and adjust certain parameters.

### Illustration

This screen can be only accessed in online mode.

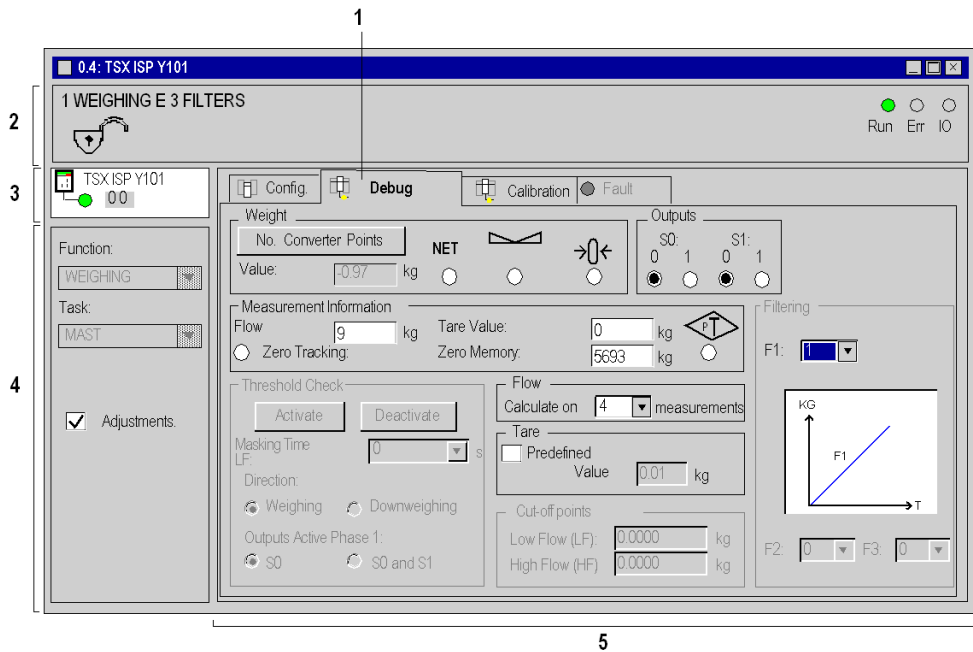

## Description

The following table shows the various parts of the debug screen and their functions.

Address	Element	Function
1	<b>Tab</b>	The tab in the foreground indicates the current mode ( <b>Debug</b> for this example). Each mode may be selected by the corresponding tab.
2	<b>Module zone</b>	Shows the abbreviated name of the module. In online mode, this zone also contains the three LEDs <b>Run</b> , <b>Err</b> and <b>IO</b> .
3	<b>Channel field</b>	Is used: <ul style="list-style-type: none"> <li>● By clicking on the reference number, to display the tabs: <ul style="list-style-type: none"> <li>○ <b>Description</b>, which gives the characteristics of the device.</li> <li>○ <b>I/O Objects</b> (see <i>EcoStruxure™ Control Expert, Operating Modes</i>), which is used to presymbolize the input/output objects.</li> <li>○ <b>Fault</b>, which shows errors detected in the module (in online mode).</li> </ul> </li> <li>● To select the channel,</li> <li>● To display the <b>Symbol</b>, name of the channel defined by the user (using the variable editor).</li> </ul>
4	<b>General parameters zone</b>	Comprises: <ul style="list-style-type: none"> <li>● the dropdown <b>Function</b> menu,</li> <li>● the dropdown <b>Task</b> menu defining the task (<b>MAST</b> or <b>FAST</b>) in which the implicit exchange objects of the channels will be exchanged.</li> <li>● the <b>Adjustments</b> check box: allows you to access the adjustment functions. When this box is ticked, an extra zone is added to the debug screen giving access to the parameters.</li> </ul>
5	<b>Display and adjustment zones</b>	Display weighing information and adjust certain module parameters.

## Description of the Module Zone of the Debug Screen

### Introduction

This zone displays general information on the module status.



### Illustration

This zone on the screen informs you about the state of the module.



### Description

The following table describes the different elements of the module screen zone and channel state.

Address	Description
 or 	Indicates whether the module is closed (locked padlock) or not.
Run	Indicator lit: normal operation Indicator unlit: module inoperable
Err	Indicator lit: internal error has made the module inoperable Indicator blinking: invalid communication or application error detected Indicator unlit: no errors detected
I/O	Indicator lit: external error detected <ul style="list-style-type: none"> <li>● overload or underload condition detected during calibration</li> <li>● range overshoot condition detected</li> <li>● incorrect measurement</li> <li>● Closed module: configuration refused</li> </ul> Indicator blinking: loss of communication with the processor Indicator unlit: external errors have been detected

## Description of the Display Zone of the Debug Screen

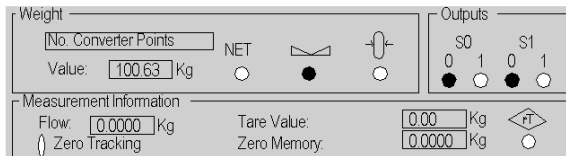

### Illustration

The dynamic display zone provides information about the weighing application.



### Description

The following table describes the different elements belonging to the weighing debug screen's display zone.

Zone	Field	Description
Weight	Number Converter Points	By default, the screen displays the current weight value. Clicking the <b>No. Converter Points</b> button will allow you to switch to points mode during the next disconnection of the PLC. The display weight will be reapplied when the PLC next runs.
	Value	The current weight value in a defined unit. If the module detects an incorrect value either on the measurement circuit or when it is in calibration mode, <b>ERR</b> is displayed on the screen.
	NET	The net weight indicator is positioned if the module returns NET weight information, otherwise this relates to gross weight.
		The "stable measurement" flag specifies that the measurement is in the defined stability range.
		The zero zone indicator is activated when the measured weight is in zero format (+/- 1/4 of the scale indicator).
Outputs		The supplied indications correspond to the physical state of outputs S0 and S1.
Measurement Information		This zone displays: <ul style="list-style-type: none"> <li>the flow value, indicated by the unit measurement</li> <li>the current tare value</li> <li>the memory zero value corresponding to zero shift from the last calibration</li> <li>the PT indicator, which specifies the tare value and has been manually introduced and not measured</li> <li>the Zero Tracking indicator, which shows that the function has been parameterized</li> </ul>

## Description of the Parameter Setting Zone

### Illustration

This zone allows you to modify the adjustment parameters.

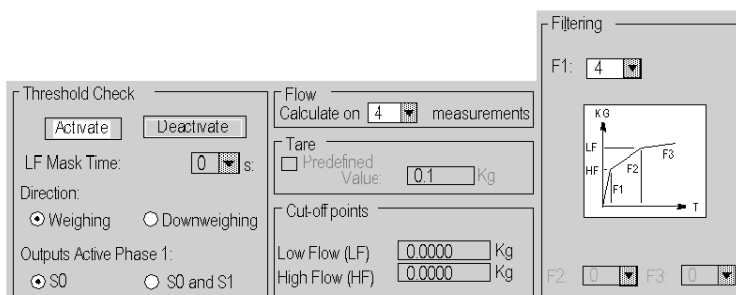

### Description

This zone allows you to modify the following parameters:

Address	Description
Filtering (see page 57)	You have the possibility to modify for each phase the filter coefficient value of the measurement input. You can choose a value from 0 to 19. <b>Note:</b> The stronger the filter (value from 1 to 11), the longer the response time.
Flow (see page 59)	You have the possibility to modify the number of measurements for the flow calculation. The listed choices carry the values 2, 4, 8, 16, 32 and 64.
Tare (see page 60)	Read only area where you could see the predefined tare value configured in local mode.
Threshold Check (see page 61)	
The following parameters are displayed only if the <b>Threshold monitoring</b> option has been activated during configuration. Recognition of parameters is effected from the confirmation command in the <b>Edit</b> menu.	
Activate	This key activates the threshold check monitoring cycle.
Deactivate	This key deactivates the threshold check monitoring cycle and positions outputs S0 and S1 into fallback mode.
LF mask time	Lets the user modify the mask time during switch to low flow.
Weighing/Down weighing direction	Lets you modify the threshold recognition.

<b>Address</b>	<b>Description</b>
Phase 1 active outputs	Lets you choose the active outputs during the first dosage phase.
Low flow (PD) and high flow (GD) cut off points	Lets you modify the threshold values.

---

# Chapter 9

## Calibrating the Scale

---

### Introduction

This chapter describes how to calibrate the measurement string.

### What Is in This Chapter?

This chapter contains the following topics:

Topic	Page
Introduction to the Calibration Function	120
Description of the Calibration Screen	122
Calibrating the Analog Measurement System	124
Calibrating the Analog Measurement System by Program	126
How to Perform a Forced Calibration	128
Performing a Forced Calibration by Program	129
How to Make a Software Calibration with a TSX ISP Y101, V2.1	130
How to Make a Software Calibration with a TSX ISP Y101, V2.2 or Later	132

## Introduction to the Calibration Function

### Introduction

The calibration of the analog measurement system consists in making a weight value correspond to an electrical signal transmitted by sensors.

This adaptation is made on site when the product is set up. It is a mandatory step to validate the measurements.

**NOTE:** The calibration function, forced or not, is only accessible in the offline mode with the PLC in Run mode.

### Calibration Rules

Any non-calibrated module is in a detected channel error state (that can be seen in the debug screen or on the module by the flashing of channel 0).

Confirm that the first calibration is complete:

1. Zero Load
2. Standard Load
3. Save

Otherwise, the information returned is not valid.

It is not possible to carry out a calibration if the PLC processor is fitted with a Flash-EEPROM memory card (**TSX MFP P 128K** or **TSX MFP P 224K** or **TSX MFP P 384K**).

Calibration can be redone throughout the module's life. The electronics characteristics do not require regular recalibration. However, legal constraints or the application's mechanical characteristics may require calibration, particularly for commercial transactions.

**NOTE:** Calibration is independent of the configured filter, but acknowledges measurement and stability information parameters.

### Calibration Type

You can choose one of the following 3 calibration types:

- normal calibration (Perform the calibration function with a standard load calibration that is greater than or equal to 70% of the maximum weight.)
- graded calibration (if a normal calibration cannot be performed under the conditions previously described)
- forced calibration:
  - CPU -> Module: being able to restore adjustments made to a different module in the event of a maintenance concern or duplication
  - Module -> CPU: being able to make the processor parameters conform with the parameters of a calibrated module that is connected to a new slot
- software calibration that requires the firmware version of the weighing module to be  $\geq 2.1$ .

### How to use TSXISPY101 calibration by program

Enhancement has been done to the TSXISPY101 module from version V2.2 (since CPU V2.6) to enable some advanced functions about the calibration by program. In particular the soft and forced calibration.

[Click here](#) to obtain information and examples (in English) on how to use the calibration by program.

## Description of the Calibration Screen

### Introduction

The adjustment screen provides access to the calibration commands.

### Illustration

This screen is accessible in online mode only.

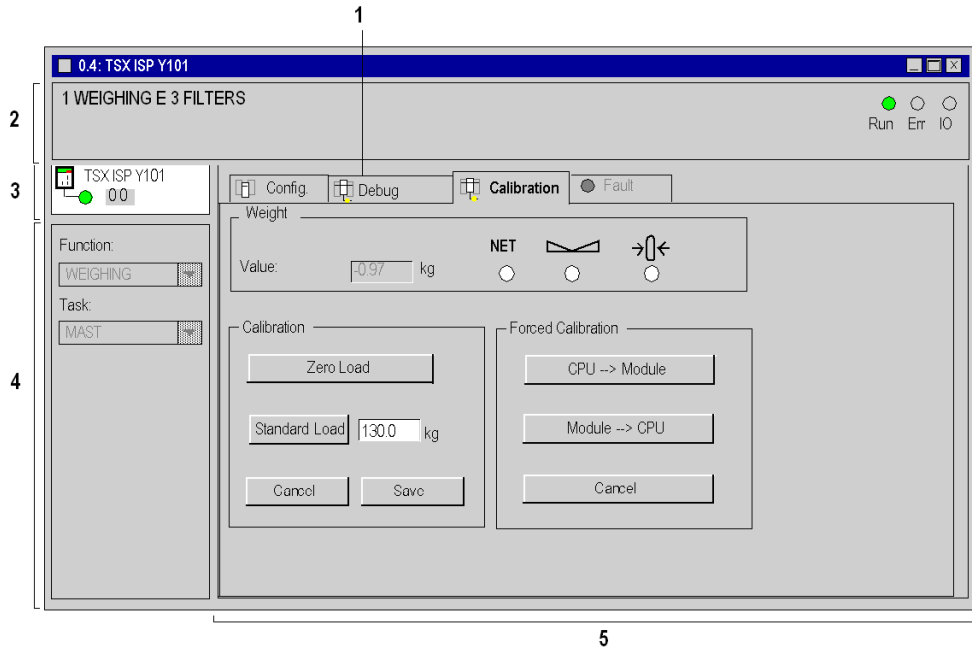

## Description

The following table shows the different elements of the calibration screen and their functions.

Address	Element	Function
1	<b>Tab</b>	The front tab indicates the current mode ( <b>Calibration</b> in this example). Each mode may be selected by the corresponding tab.
2	<b>Module zone</b>	Shows the abbreviated name of the module. In online mode, this zone also contains the three LEDs <b>Run</b> , <b>Err</b> , and <b>IO</b> .
3	<b>Channel field</b>	Is used: <ul style="list-style-type: none"> <li>● by clicking on the module reference to display the <b>Description</b> tab, which contains the technical specifications and the <b>Fault</b> tab, which contains any error conditions detected in the module</li> <li>● to select the channels you wish to configure</li> </ul>
4	<b>General parameters zone</b>	Comprises the: <ul style="list-style-type: none"> <li>● dropdown <b>Function</b> menu</li> <li>● dropdown <b>Task</b> menu defining the task (<b>MAST</b> or <b>FAST</b>) in which the implicit exchange objects of the channels will be exchanged</li> </ul>
5	<b>Display and calibration zones</b>	Displays weighing information ( <i>see page 116</i> ) and the calibration commands ( <i>see page 124</i> ).

**NOTE:** The copy of the calibration parameters from the module to the CPU is lost after an application transfer.

## Calibrating the Analog Measurement System

### Introduction

Calibration can be carried out on a Control Expert station connected to the PLC using the calibration screen.

It can also be done using an operator dialog, which uses Control Expert language instructions.

**NOTE:** The procedure can be stopped at any time by pressing **Cancel**. The module reverts to the previous parameters. The current calibration parameters are therefore lost.

The procedure is only enabled if the module has been calibrated correctly.

If there is measurement saturation, the new parameters cannot be saved. Either correct the detected error or cancel the procedure, using **Cancel**.

### Procedure

This table describes the procedure for calibrating the analog measurement system.

Step	Action	Result
1	Switch the rack on.	The product is initialized, carries out self-tests and receives its configuration.
2	Access the calibration screen while the processor is in RUN mode and the terminal is in online mode:: <ol style="list-style-type: none"> <li>1. Select <b>Configuration</b> in the project browser.</li> <li>2. Click the module's slot.</li> <li>3. Select the <b>Calibration</b> tab.</li> </ol>	-
3	Check that the counter output is empty.	-
4	Click the <b>Zero Load</b> button to carry out zero load calibration (recognized by the load receiver).	This phase requires around 20 seconds. An hour glass appears until the operation is complete. The module reports an error condition and any measurement is invalid. The status of the flag %lwr.m.0.4.6 <b>Calibration_in_progress</b> changes. The module indicates the acquisition of the zero weight reference and processes the reports.
5	Place calibration weight.	-
6	Enter the calibration weight value in the "Standard Load" field (the value of the maximum weight), and click the <b>Standard Load</b> button. If the command is disabled, an error message appears.	This phase requires around 20 seconds. The module checks the standard load weight against the maximum weight. The status of the flag %lwr.m.0.4.6 <b>Calibration_in_progress</b> changes. The module acquires the standard load weight reference, processes and positions the report.

---

Step	Action	Result
7	Click the <b>Save</b> button to recognize the parameters resulting from calibration.	The module and the processor recognize and save the parameters resulting from calibration. During the write phase, the measurement keeps reporting a channel error until the writing is complete. Measurement restarts when writing is finished. The measurement is valid.

**NOTE:** If you skip steps 5 and 6 in this table, a default gain is applied.

## Calibrating the Analog Measurement System by Program

### Introduction

Several language elements are used to implement and supervise the calibration mechanism.

The calibration screen facilitates the procedure, but it can also be performed by program using reserved data.

### Procedure

Program the following operations to perform a calibration.

Step	Action	Result	
1	Zero weight	Enter <code>WRITE_CMD</code> while setting the calibration order of the channel using the zero weight ( <code>%MWr.m.0.3.1=1</code> ).	The status of the <code>%IWr.m.0.4.6</code> <b>Calibration in progress</b> indicator changes. This operation enables you to determine the <b>Offset</b> parameter.
2	Standard Load	Load the standard load weight value in the following words (high resolution format): <ul style="list-style-type: none"> <li>● <b>Premium/Atrium</b>: <code>%MDr.m.0.4</code></li> <li>● <b>M580</b>: <code>%MWr.m.0.4</code> &amp; <code>%MWr.m.0.5</code></li> </ul>	-
3		Enter <code>WRITE_CMD</code> while setting the calibration order of the channel using the standard load weight ( <code>%MWr.m.0.3.2=1</code> , or <code>%MWr.m.0.3.12=1</code> for a graded calibration).	The <code>%IWr.m.0.4.6</code> <b>Calibration in progress</b> indicator changes status. This operation is used to determine the <b>Gain</b> parameter.
4	Save the parameters in the module.	Enter <code>WRITE_CMD</code> while setting the save order of the calibration in the module ( <code>%MWr.m.0.3.0=1</code> ).	-
5	Copy the module parameters in the CPU.	Enter <code>WRITE_CMD</code> while setting the save order of the calibration in the processor ( <code>%MWr.m.0.3.11=1</code> ).	-

## Summary of the Data Used

The following table describes the data involved in a calibration.

Type	Role	Associated Data
Command type	Save calibration in the module	%MWr.m.0.3.0
	Zero weight	%MWr.m.0.3.1
	Standard load weight (Normal)	%MWr.m.0.3.2
	Forced calibration (CPU -> Module)	%MWr.m.0.3.10
	Save calibration in the processor	%MWr.m.0.3.11
	Standard load weight (Graded)	%MWr.m.0.3.12
Command parameter	Value of standard load weight	<b>Premium/Atrium:</b> %MDr.m.0.4 <b>M580:</b> %MWr.m.0.4 & %MWr.m.0.5
Report	Calibration in progress (Normal)	%IWrr.m.0.4.6
	Instability	%IWrr.m.0.4.9
	Overload or underload during calibration	%%MWr.m.0.2.0
	Non-calibrated module	%MWr.m.0.2.9
	Calibration mode	%MWr.m.0.2.14
	Forced calibration mode	%MWr.m.0.2.15

## How to Perform a Forced Calibration

### Introduction

This function responds to the needs of speedy maintenance.

Forced calibration allows calibration values from a weighing module to be transferred to the CPU and vice versa.

**NOTE:** This action cannot be reversed. Once the transfer has occurred, it is not possible to cancel the command.

**NOTE:** This function is accessible in online mode only, with the PLC in Run.

**NOTE:** After an application is transferred to the CPU, the calibration values are reset. The values are transferred from the module to the CPU.

### Operating Mode

Transferring the CPU to the weighing module is authorized after the CPU has the requisite calibration parameters for the desired slot.

Transferring the weighing module to the CPU requires the module to be calibrated (but not through a forced calibration).

### Procedure

This table describes the procedure to make a forced calibration:

Step	Action
1	Switch the rack on.
2	Access the calibration screen: <b>1.</b> Select <b>Configuration</b> . <b>2.</b> Click the module's slot. <b>3.</b> Select the <b>Calibration</b> tab.
3	In the <b>Forced Calibration</b> field, click either <b>CPU --&gt;Module</b> or <b>Module --&gt;CPU</b> , according to the desired transfer direction.

**NOTE:** The procedure is not enabled unless the transfer is performed correctly. If the transfer is incorrect, click the **Cancel** button in the **Forced Calibration** field.

## Performing a Forced Calibration by Program

### Introduction

Several language elements are used to implement and supervise the calibration mechanism.

The calibration screen facilitates the procedure, but it can also be performed by program using reserved data.

### Procedure

Carry out the following operations to perform a forced calibration by program.

Direction of copy	Action	Result
CPU -> Module	Enter <code>WRITE_CMD</code> while positioning the save order of the calibration in the module (%MWr.m.0.3.10=1).	This operation is used for example when replacing a module. It enables you to automatically restore the calibration parameters in the module (gain, offset and converter configuration).
Module -> CPU	Enter <code>WRITE_CMD</code> while positioning the save order of the calibration in the processor (%MWr.m.0.3.11=1	This operation enables you to automatically restore the calibration parameters in the processor when, for example, you are using a module that is placed in a new slot. This operation is only possible if the module is calibrated.

## How to Make a Software Calibration with a TSX ISP Y101, V2.1

### Introduction

Calibration can be carried out on a Control Expert station connected to the PLC with a TSX ISP Y101 module (firmware version 2.1) using the calibration screen.

**NOTE:** Software calibration cannot be used for regulated weighing applications.

### Procedure

The following procedure applies only to TSX ISP Y101 weighing modules with firmware version 2.1.

This table describes the procedure for calibrating the analog measurement system:

Step	Action	Result
1	Switch the rack on.	The product is initialized, carries out self-tests and receives its configuration.
2	<p>Access the calibration screen while the processor is in RUN mode and the terminal is in online mode::</p> <ol style="list-style-type: none"> <li>1. Click the module's slot.</li> <li>2. Select the <b>Configuration</b> tab: <ul style="list-style-type: none"> <li>○ Set the Maximum Range (MR) to a value higher than the sum of the sensors' weight ratings.</li> <li>○ Set the Low Flow (LF) to a value equal to the average of the sensors' sensitivities.</li> <li>○ If needed, set the Scale Division (e) to less than 1.</li> </ul> </li> <li>3. <b>Validate.</b></li> <li>4. Select the <b>Calibration</b> tab.</li> </ol>	-
3	Check that the counter output is empty.	-
4	Press the <b>Zero Load</b> button.	<p>The module reports an error condition and any measurement is invalid.</p> <p>The status of the flag %lwr.m.0.4.6 <b>Calibration_in_progress</b> changes.</p> <p>The module acquires the standard load weight reference, processes and positions the report.</p>
5	<p>In the <b>Standard Load</b> field, enter the value PN.xx where PN corresponds to the sensors' weight ratings and xx is not 0.</p> <p>If the command is disabled, an error message appears.</p>	<p>The status of the flag %lwr.m.0.4.6 <b>Calibration_in_progress</b> changes.</p> <p>The module calculates the theoretical calibration coefficients.</p>

---

Step	Action	Result
6	Click the <b>Save</b> button to recognize the parameters resulting from calibration.	The module and the processor recognize and save the parameters resulting from calibration. During the write phase, the measurement keeps reporting a channel error until the writing is complete. Measurement restarts when writing is finished. The measurement is valid.
7	Select <b>Configuration</b> tab, reset (MR), (LF) and (e) to their initial configuration values and <b>validate</b> .	

## How to Make a Software Calibration with a TSX ISP Y101, V2.2 or Later

### Introduction

Calibration can be carried out on a Control Expert (Unity Pro 6.0 or later) workstation connected to the PLC with a TSX ISP Y101 module (firmware version 2.2 or later) using a program using reserved data.

We recommend using the generic application for software calibration with operation screens that is available from the Schneider Electric web site.

The procedure below allows you to program your own application to calibrate the TSX ISP Y101, V2.2 or later, module.

**NOTE:** Software calibration cannot be used for regulated weighing applications.

### Calibration Procedure

#### WARNING

##### UNINTENDED EQUIPMENT OPERATION

The application of this procedure requires expertise in the programming of control systems. Only persons with such expertise are allowed to apply this procedure.

**Failure to follow these instructions can result in death, serious injury, or equipment damage.**

To perform a valid calibration, perform these steps in the following order:

Step	Action
1	Initialization: Reset previous CMD and save current F1 (filter coefficient): <ul style="list-style-type: none"> <li>● Set %MWr.m.0.3 = 0.</li> <li>● Use the READ_PARAM for %MWr.m.0.6.</li> <li>● F1 = %MWr.m.0.6.</li> </ul>
2	Check that the scale is empty.
3	Enable software calibration by using WRITE_PARAM to set the value of filter F1. (1 < %MWr.m.0.6 < 19)
4	Set the Zero Load to determine the Offset parameter: <ul style="list-style-type: none"> <li>● Use the WRITE_CMD to set the calibration order of the channel using the zero weight (%MWr.m.0.3.1 = 1)</li> <li>● Check that %MWr.m.0.0 exchange is in progress.</li> <li>● Check that %MWr.m.0.1 reports successful completion of the CMD.</li> <li>● The status of the %IW.r.m.0.4.6, the Calibration in Progress indicator, changes.</li> </ul> <p><b>NOTE:</b> Do not <b>Save</b> until steps 5 and 6 are completed.</p>

Step	Action
5	<p>Using the number of load cells, the sum of the maximum load of each load cell and average of the sensitivities of the sensors, the module calculates the theoretical calibration coefficients.</p> <ul style="list-style-type: none"> <li>● For a <b>Premium/Atrium PLC</b>, set %MDr.m.0.4 to S.</li> <li>● For a <b>M580 PLC</b>, set %MWr.m.0.4 and/or %MWr.m.0.5 to S.</li> </ul> <p>Where S (type DINT) is the result of the following calculation:</p> <ul style="list-style-type: none"> <li>○ <math>S = s * (MR/ML) * 100/p</math></li> <li>○ s = average of sensor sensitivities (mv/v) if more than one sensor is in your system</li> <li>○ ML = (sensor number)*(sensor Maximum Load)</li> <li>○ MR = maximum range configured in the measurement data</li> <li>○ p = precision scale, refer to Available Sensitivity (<i>see page 134</i>)</li> </ul> <p><b>NOTE:</b> According to the usual values of the above parameters, the S value is between 10 and 400,000.</p> <ul style="list-style-type: none"> <li>● <b>An example</b> <ul style="list-style-type: none"> <li>○ unit = kg</li> <li>○ p = 0.01 (default precision scale)</li> <li>○ MR = 12 kg (maximum range configured)</li> <li>○ ML = 4*3.5 kg (4 sensors with a maximum load of 3.5 kg)</li> <li>○ <math>s = 1.92345 \text{ mV/V}</math> (<math>s = (s1 + s2 + s3 + s4)/4</math>, where s1, s2, s3 and s4 are the sensitivity values of the 4 sensors from the load cell)</li> </ul> </li> <li>● The results are: <ul style="list-style-type: none"> <li>○ <math>S = s * (MR/ML) * 100/p</math> S = 16486</li> <li>○ S is within the <math>10 &lt; S &lt; 400\ 000</math> range.</li> </ul> </li> </ul> <p>Calculation of the theoretical calibration coefficients:</p> <ul style="list-style-type: none"> <li>● Use the WRITE_CMD to set the calibration order of the channel using the standard load weight (%MWr.m.0.3.2 = 1).</li> <li>● Check that %MWr.m.0.0 exchange is in progress.</li> <li>● Check that %MWr.m.0.1 reports successful completion of the CMD.</li> <li>● The status of the %IWr.m.0.4.6, the Calibration in Progress indicator, changes.</li> </ul>
6	<p>Save the parameters in the module:</p> <ul style="list-style-type: none"> <li>● Use the WRITE_CMD to set the save order of the calibration in the module (%MWr.m.0.3.0 = 1).</li> <li>● Check that %MWr.m.0.0 exchange is in progress.</li> <li>● Check that %MWr.m.0.1 reports successful completion of the CMD.</li> <li>● The status of the Calibration_in_progress flag (%Iwr.m.0.4.6) changes.</li> </ul>
7	<p>Restore Previous F1 by using WRITE_PARAM to set the previous value of the filter to F1. %MWr.m.0.3.0.6 = F1, the default is 4</p>
8	<p>Copy the module parameters in the CPU:</p> <ul style="list-style-type: none"> <li>● Use the WRITE_CMD to set the save order of the calibration in the processor (%MWr.m.0.3.11 = 1).</li> <li>● Check that %MWr.m.0.0 exchange is in progress.</li> <li>● Check that %MWr.m.0.1 reports successful completion of the CMD.</li> <li>● The status of the Calibration_in_progress flag (%Iwr.m.0.4.6) changes.</li> </ul>

**Available Sensitivity**

The available sensitivity depends on the value of the precision scale p.

This table shows the relationship between the Division and Precision scales:

Division Scale (d)	Precision Scale (p)	Sensitivity Example using 1.92345
0.001	0.001	1.92345
0.002	0.001	1.92345
0.005	0.001	1.92345
0.01	0.01	1.9234
0.02	0.01	1.9234
0.05	0.01	1.9234
0.1	0.1	1.923
0.2	0.1	1.923
0.5	0.1	1.923
1	1	1.92
2	1	1.92
5	1	1.92
10	1	1.92
20	1	1.92
50	1	1.92
100	1	1.92
200	1	1.92
500	1	1.92
1000	1	1.92
2000	1	1.92
5000	1	1.92

---

# Chapter 10

## Protecting the Adjustments

---

### Introduction

This chapter describes how to protect the adjustments done during the previous phases.

### What Is in This Chapter?

This chapter contains the following topics:

Topic	Page
Protection of the Weighing Parameter Settings	136
How to Protect the Adjustments	138
Legal Metrology and Regulations	139

## Protection of the Weighing Parameter Settings

### Introduction

Any weighing instrument that can be used for commercial transactions requires approval. The parameters associated with the measurement require protection. It should not be possible to introduce into an instrument, via the interface, instructions or data likely to:

- falsify the weighing results displayed
- change an adjustment factor

**NOTE:** Protection by sealing helps provide measurement conformity so that the parameters accessible only apply to the exploitation aspects of the module information by the mechanism.

### Effect of Protecting the Configuration Parameters

There are two types of information:

- information that can be protected  
(If a module is sealed, this type of information will be available in read only.)
- information with free access (read and write)

The following table identifies the characteristics of this information according to the protection put in place.

Functions	Without Sealing	With Sealing
Task	Modifiable	Modifiable
Flow/ Calculation on n measurements	Modifiable	Modifiable
Tare/ Predefined	Modifiable	Modifiable
Threshold checking/ Active	Modifiable	Modifiable
Threshold checking/ Direction	Modifiable	Modifiable
Threshold checking/ Active outputs	Modifiable	Modifiable
Threshold Checking/ Cut-off points	Modifiable	Modifiable
Threshold checking/ LV Mask Time	Modifiable	Modifiable
Unit	Modifiable	Non modifiable
Max Range (MR)	Modifiable	Non modifiable
Scale Division	Modifiable	Non modifiable
Overload Threshold	Modifiable	Non modifiable
Filtering/ Coefficient	Modifiable	Modifiable
Data format	Modifiable	Non modifiable
Stability/Extent of Range	Modifiable	Non modifiable

Functions	Without Sealing	With Sealing
Stability/Time	Modifiable	Non modifiable
Zero/Zero tracking	Modifiable	Non modifiable
Zero/Recalibration range	Modifiable	Non modifiable

The information word %lwr.m.0.4.4 (to 1) tells you if the measurement is protected.

### Consequences of Protection

- A sealed module that receives a different configuration from the one memorized (before being switched off prior to the movement of the jumper) is refused.
- In this case the module is seen as missing in the PLC diagnostics, but sends a weight to the display.
- A sealed module will not accept a new calibration request.

**NOTE:** Using the file allows you to keep a paper record of the configuration.

## How to Protect the Adjustments

### Necessary Conditions

Confirm that the calibration and adjustment operations are completed.

### Illustration

The following illustration shows how to position the jumpers in order to protect the adjustments.

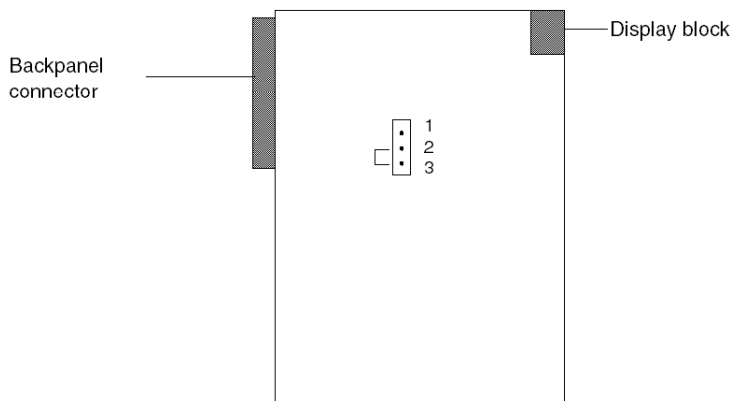

### Procedure

The following table describes the operation of protecting the adjustments (leading).

Step	Action
1	Take the module out of the PLC rack (the rack can remain switched on).
2	Remove the module's casing (use a TORX type screwdriver for this).
3	Place the jumper in position 2-3 as shown in the illustration.
4	Put the module back into its casing.
5	Replace the module in the rack in its previous position.

## Legal Metrology and Regulations

### EU Approval

The set consisting of: load holder + sensors + module can be considered as an IPFNA (non automatic weighing instrument).

As such, and to be able to use it for commercial transactions, it has been approved by the EU.

If it is only used for internal processes, confirm that the display has an identification plate mentioning:

Trademark	Max =
Type of instrument	e =
Serial number	
'All transactions prohibited'	

If it is for regulated uses (e.g. commercial transactions), place an identification plate on the display, showing:

Trademark	Max =
Type of instrument	Min =
Serial Number	e =
Number and date of EU approval of type	Number 97.00.620.016.0 29th September 1997

Moreover, it receives a first check on leaving the factory, as well as regular on-site monitoring by a licensed body. Generally, monitoring takes place once a year, and this is the responsibility of the owner.

### Approval of the Model

#### Measurement and control device for filling machine and a discontinuous counter

This IPFNA can be supplemented with the specific software applications 'Filling Machine' or 'Discontinuous counter'. As such, it has passed national approvals, as a measurement and automatic control device for filling machines and discontinuous counters.

**NOTE:** It is up to the manufacturer of the measurer or discontinuous counter to get a complete approval of any automatic weighing instruments made up in this way, in the most straightforward conditions possible.

It is also up to the manufacturer of the machine to install the identification plate and to present the machine for its first check, when necessary.

### Approval of a continuous counter model

Associated with a weighing table, it is authorized as a continuous counter device.

Except for when used for commercial transitions, the identification plate shows:

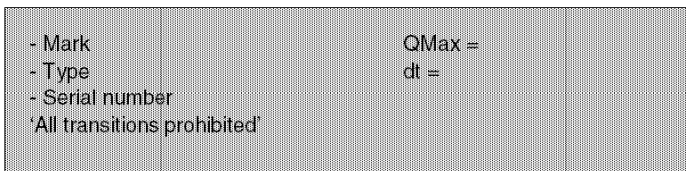

When used for commercial transitions, the identification plate shows:

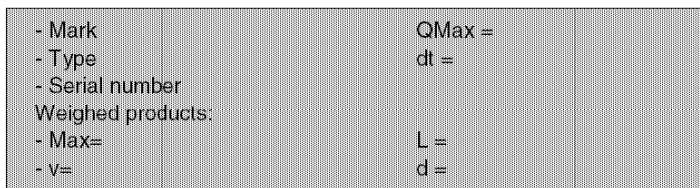

The first phase of the mandatory check is done in the factory on the complete instrument uncoupled from its conveyor, by means of a movement simulator; the other phases are carried out on the complete instrument.

### Class of Appliance

With average precision, the appliance covers the range from the minimum (500 scale divisions) up to 6000 scale divisions. These instruments can be authorized or unauthorized to carry out commercial transitions. If it is unauthorized, 'PROHIBITED FOR ALL TRANSACTIONS' is written on the appliance's front panel.

---

# Chapter 11

## Operating a Weighing Application

---

### Introduction

This chapter describes the tools that allow you to operate a weighing application.

### What Is in This Chapter?

This chapter contains the following topics:

Topic	Page
Ways of Displaying Weighing Information	142
Description of the Display Report	143
Weighing Module Operating Modes	145

## Ways of Displaying Weighing Information

### Description

The following table describes the different ways of displaying weighing information.

Ways	Description
module display panel <b>TSX XBT N410</b> <i>(see page 143)</i>	Automatically displays the weight measurement without any prior programming.
debugging screen <i>(see page 116)</i>	Displays information relevant to the weighing and allows the modification of certain parameters.
animation tables	Information about the measurement can be accessed as PLC variables and can be displayed in the animation tables.
operation screen	It is possible to create runtime screens using the weighing language objects in order to display the information required to run the application.
supervision	The weighing language objects can be conveyed and operated by a supervision system.

### Language Objects

The following language objects are used for operating the weighing application.

Displayed Data	Object Address
protected module	%MWr.m.0.2.8 (Explicit Exchange Object)
non-calibrated module	%MWr.m.0.2.9 (Explicit Exchange Object)
weight value	%IDr.m.0.0
net weight flag	%IWrr.m.0.4.8
stability flag	%IWrr.m.0.4.9
zero indicator	%IWrr.m.0.4.10
discrete S0 output status	%IWrr.m.0.4.0
discrete S1 output status	%IWrr.m.0.4.1
flow	%IDr.m.0.2
tare value	<b>Premium/Atrium:</b> %IDr.m.0.5 <b>M580:</b> %IDr.m.0.6
recalibration memory	<b>Premium/Atrium:</b> %IDr.m.0.7 <b>M580:</b> %IDr.m.0.8
zero indicator follower	%IWrr.m.0.4.11
predetermined tare flag	%IWrr.m.0.4.12

## Description of the Display Report

### Introduction

The **TSX XBT N410** display module provides measurement indications (see **TSX XBT N410** installation documentation).

This display appears automatically without prior programming.

### Illustration

The following illustration shows **TSX XBT N410** display.

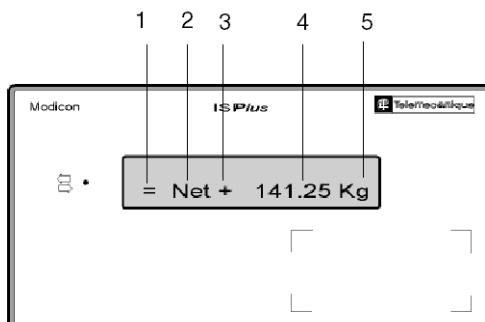

**NOTE:** On the **TSX XBT N410**, space is left available for the punched identification plate to meet legal measurement requirements.

### Description of the Display

Valid measurements are transmitted to the display in physical units with a fixed number of decimal places, every 100 ms.

The following table describes the indications that may appear on the display in normal operation.

Address	Indication	Description
1	=	The measurement is stable.
	none	The measurement is not stable (the stability criteria are defined in the configuration).
2	Net	The measurement indicates a Net weight.
	none	The measurement indicates a gross weight.

Address	Indication	Description
3	+	The measurement is positive.
	0	The measurement is approximately 0 (between -1/4 et +1/4 scale division).
	-	The measurement is negative: <ul style="list-style-type: none"> <li>● if the associated numerical value blinks: the measurement is between -9 scale divisions and -1/4 scale division,</li> <li>● if no associated numerical value is displayed: the measurement is below -9 scale divisions.</li> </ul>
4	141.25	Numerical value of the weight.
5	kg	Symbol of measurement mass unit: g for gram, kg for kilogram, lb for pound, oz for ounces and t for metric tonne.

**NOTE:** The serial link test is carried out when the weighing module is powered up. The **TSX XBT N410** display module should be connected to the **TSX ISP Y101** when the PLC is powered up.

### Error Messages

The following table describes the indications that may appear on the display.

Indication	Description
-----	The measurement is not valid, a channel error is detected.
>>>>	An overload is detected.
<<<<	An underload is detected.
Time out	The display no longer receives data from the weighing module.
Checksum error	An error was detected during the power-up. At power-up, the <b>TSX XBT N410</b> performs a test on its resources. In operation, all the information received is checked. If a <b>Checksum</b> mismatch occurs, the <b>Checksum</b> error is displayed.

## Weighing Module Operating Modes

### Operation

The following illustration describes the operation of the module.

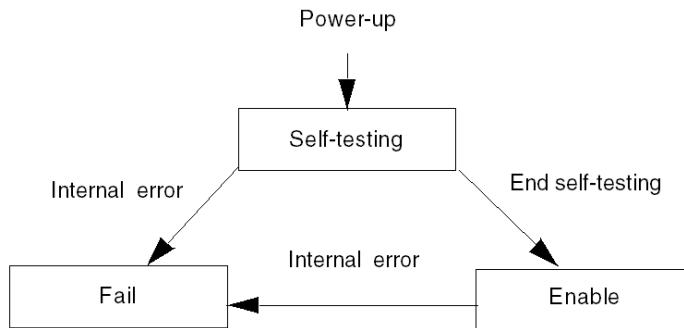

### Behavior on Encountering an Error

During power-up, the module carries out its own self-tests (REEPROM , RAM, Link display, etc.).

If an error is detected at the end of these tests, the module switches to fail back mode, the outputs are at 0.

Similarly, if, when operating normally, the module detects an internal error (in RAM or the watchdog, for example), the outputs are positioned to 0 and the display shows dashes (----) on the screen.

### Behavior on Power Outage

On power outage the machine parameters are saved (Tare mode, Zero offset, etc.) whereas the operating parameters are lost (Thresholds, number of measurements used to calculate flow rate, etc.).



---

# Chapter 12

## Diagnostics of the Weighing Application

---

### Introduction

This chapter allows you to diagnose the errors detected in the weighing application.

### What Is in This Chapter?

This chapter contains the following topics:

Topic	Page
How to Access the Diagnostics Function of the Weighing Module	148
How to Access the Channel Diagnostics Function of the Weighing Module	149

## How to Access the Diagnostics Function of the Weighing Module

### Introduction

The module diagnostics function displays error messages when they occur, classified as follows:

- internal (module inoperable, running self-test)
- external (terminal block error)
- other (configuration mismatch, module missing or switched off, channel errors (details in channel diagnostics))

A module error is indicated by certain LEDs changing to red, such as:

- in the rack-level configuration editor:
  - the module position LED
- in the module-level configuration editor:
  - the **Err** and **I/O** LEDs, depending on the type of error
  - the **Fault** tab LED

### Procedure

The following table describes the procedure for accessing the module diagnostics screen.

Step	Action
1	Access the module configuration screen.
2	<p>Click the module reference in the channel zone and select the <b>Fault</b> tab.</p> <p><b>Result:</b> The list of module errors appears.</p> <div data-bbox="334 907 1053 1203" data-label="Image"> <p>The screenshot shows a diagnostic interface with three main sections: 'Internal errors', 'External errors', and 'Other errors (Faulty channel(s))'. Each section is represented by a rectangular box, currently empty, indicating no errors are present in those categories.</p> </div> <p><b>Note:</b> It is not possible to access the module diagnostics screen if a configuration mismatch or inoperable or missing module error occurs. The following message appears on the screen: The module is missing or different from that configured for this position.</p>

## How to Access the Channel Diagnostics Function of the Weighing Module

### Introduction

The Channel diagnostics function displays error messages when they occur, classified according to category:

- internal (inoperable channel)
- external (link or sensor link power supply lost)
- other (terminal block error, configuration mismatch, communication error)

An inoperable channel is indicated when the **Fault LED**, situated on the **Fault** tab of the configuration editor, switches to red.

### Procedure

The table below shows the procedure for accessing the Channel diagnostics screen.

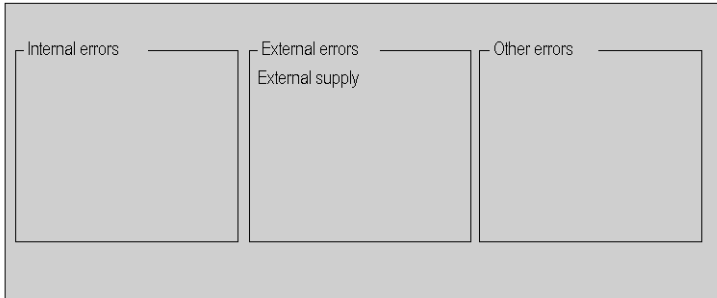
Step	Action
1	Access the weighing module configuration screen.
2	<p>Select the <b>Fault</b> tab.  <b>Result:</b> The list of channel diagnostics appears.</p>  <p>The screenshot shows a window with three columns. The first column is labeled 'Internal errors'. The second column is labeled 'External errors' and has 'External supply' listed below it. The third column is labeled 'Other errors'.</p> <p><b>Note:</b> Access to the channel diagnostics information is also possible by program (instruction READ_STS).</p>



---

# Chapter 13

## Examples of the Weighing Program

---

### Introduction

This chapter provides programming examples for a weighing application.

### What Is in This Chapter?

This chapter contains the following topics:

Topic	Page
Example of a Tare Mode	152
Example of Metering Flow	153

## Example of a Tare Mode

### Introduction

This example illustrates the main steps of a weighing process: it deals with carrying out a switch into NET weight (tare mode).

### Example

The `TARE_ORDER` bit is used for this action. Its positioning causes the gross weight, which is currently measured as the weighed tare, to be acknowledged, then it causes the display to be switched to NET mode.

The `WEIGHT_1` variable of type `T_WEIGHING_ISPY101` is associated with channel 0 of the weighing module situated in rack 6.

```
(*Closed weighing module, slot 6*)
(*Waiting for tare mode conditions*)
IF Tare_request THEN
    SET (Tare_order);
    RESET (Tare_request);
    RESET (Tare_done);
    RESET (Tare_error);
END_IF;

(*Tare mode*)
(*Send tare mode order*)
IF Tare_order AND NOT Tare_ended AND NOT WEIGHT_1.CMD_ERR
AND NOT WEIGHT_1.CMD_IN_PROGR AND NOT WEIGHT_1.STABILITY THEN
    WEIGHT_1.CMD_TYPE:=0;
    SET (WEIGHT_1.TARE_CMD);
    WRITE_CMD (WEIGHT_1);
    RESET (Tare_order);
    SET (Tare_ended);
END_IF;

(*Tare mode ended and OK*)
IF Tare_ended AND NOT WEIGHT_1.CMD_ERR AND NOT WEIGHT_1.CMD_IN_PROGR
AND NOT WEIGHT_1.IN_PROGR THEN
    SET (Tare_done);
    WEIGHT_1.CMD_TYPE:=0;
    RESET (Tare_ended);
ELSE
    (*Tare mode refused => error*)
    IF Tare_ended AND WEIGHT_1.CMD_ERR THEN
        SET (Tare_error);
        WEIGHT_1.CMD_TYPE:=0;
        WEIGHT_1.CANCEL_CMD:=1;
        WRITE_CMD (WEIGHT_1);
        RESET (Tare_ended);
    END_IF;
    WEIGHT_1.CMD_TYPE:=0;
END_IF;
```

## Example of Metering Flow

### Introduction

The following example uses a weighing module in slot 2 of the PLC.  
It describes a metering flow in stages.

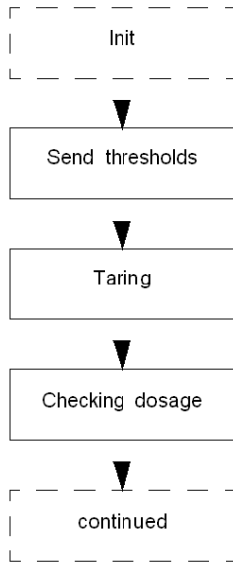

## Example

The program is processed in structured text. The WEIGHT\_1 variable of type WEIGHING\_ISPY101 is associated with channel 0 of the weighing module situated in rack 6.

### Main Program

```
(* /////////// Send thresholds /////////// *)
L100:
  IF NOT %M99 THEN
    JUMP L120;
  END_IF;

(*Loading and sending thresholds *)
  IF RE (%M99) THEN
    WEIGHT_1.HF_CUT:=%MD230;(* S0 High Flow cut-off point*)
    WEIGHT_1.LF_CUT:=%MD232;(* S1 Low Flow cut-off point*)
    WRITE_PARAM (WEIGHT_1);JUMP L120;
  END_IF;

(*Transmission in progress*)
  IF WEIGHT_1.ADJ_IN_PROGR THEN
    JUMP L120;
  END_IF;

(*command accepted*)
  IF NOT WEIGHT_1.ADJ_ERR THEN
    RESET (%M99);
  END_IF;

(*FIN INIT CYCLE*)
  L120:

(* /////////// TARE MODE PHASE      (%MW100 =4) /////////// *)

L260:
  IF %MW100<>4 THEN
    JUMP L300;
  END_IF;

(*Tare mode request *)
  IF %M72 THEN
    RESET (%M72);
    %MW270:2:=4;
  END_IF;

(*Management of commands *)
SR0; (* %MW270 informs you of the type of tare mode command 4 *)

(*Waiting for tare mode return*)
  IF %MW270=-1 AND %MW271=-1 THEN
    %MW100:=5;
    SET (%M72);
    JUMP L800;
  END_IF;
```

## Example (continued)

```

(* ////////////////////////////////// DOSAGE PHASE  (%MW100 = 5) ////////////////////////////////// *)
L300:
    IF %MW100<>5 THEN
        JUMP L340;
    END_IF;

(*Enable thresholds *)
    IF %M72 THEN
        RESET (%M72);
        %MW270:2:=8;
    END_IF;

(*Management of commands *)
    SR8();(* %MW270 = type of threshold enable command 8 *)

(*Waiting for command mode return*)
    IF %MW270>=0 OR %MW271>=0 THEN
        JUMP L800;
    END_IF;

(*Checking outputs to skip one after the other*)
    IF NOT WEIGHT_1.Q0_OUT AND NOT WEIGHT_1.Q1_OUT THEN
        %MW100:=6;
        SET (%M72);
        JUMP L800;
    END_IF;

(*PHASE 6 continued *)
L340:
    IF %MW100<>6 THEN
        JUMP L380;
    END_IF;

L800:
SUBROUTINE SR8 :
    (* Send request for the module*)
    IF %MW270>=0 THEN (* %MW270 informs you of the order to carry out
*)
        %M0:16:=0;
        SET (%M0[%MW270]);
        WEIGHT_1.MOD_CAL_SAVE_CMD:=%M0:16;
        %MW271:=%MW270;
        %MW270:=-1;
        WRITE_CMD (WEIGHT_1);
        RETURN;
    END_IF;

(*Command in progress? *)
    IF WEIGHT_1.CMD_IN_PROGR OR WEIGHT_1.IN_PROGR THEN
        RETURN;
    END_IF;

(*command accepted? *)
    IF NOT WEIGHT_1.CMD_ERR AND NOT WEIGHT_1.APPLI_FLT THEN
        %MW270:2:=-1;
    ELSE
        %MW270:=%MW271;
    END_IF;

```



---

# Glossary

---



## C

### **calibration**

Graduates a piece of measuring apparatus.

## D

### **discrete**

discrete I/Os

## G

### **gross weight**

Indication of the load weight on an instrument when no tare or predefining device has been used.

## I

### **IODDT**

input/output derived data type

## L

### **lead sealing**

Sealing a piece of apparatus with lead. This function is established by the positioning of a jumper in the weighing module.

The objective of this device is measurement conformity. The accessible parameters only have influence on the aspects of the mechanism's exploitation of module information. (The unit, weight, scale division, etc, are read only.)

## M

### **maximum weight (max)**

Maximum weighing capacity, not taking into account the additive capacity of the tare.

## N

### **net weight (net)**

Weight indication of a load placed on an instrument after a tare device has been used.

Net weight = gross weight - tare weight

## P

### **predefined tare value (PT)**

Numerical value, representing a weight, which is entered into the instrument at configuration or by adjustment or program.

## S

### **scale division**

Value in mass units, expressing the difference between two consecutive indications for one numerical indication.

### **set to zero device**

Device allowing the indicator to be *recalibrated* in the event of a deviation from zero (due to dirt accumulation, for example). This operation can only be carried out in the extent of zero range (+/- 2 % or +/-5 % of the maximum range according to the weighing instrument).

## T

### **tare**

Load placed on the load receiver along with the product to be weighed. For example: product packaging or container.

### **taring**

Action allowing the instrument indication to be moved to zero when a load is positioned on the load receiver.

## Z

### **zero tracking**

Device allowing slow derivations from zero to be made up, within the limits of the extent of the zero range.



## C

calibrating, *119*  
channel data structure for weighing modules  
    T\_WEIGHING\_ISPY101, *82*  
configuring, *47*  
connecting, *29*

## D

debugging, *111*  
diagnostics, *147*  
display units, *141*

## F

filtering, *57*  
flow calculations, *59*

## I

installing, *19*

## M

measurement data, *52*  
measurement system  
    tare, *20*

## P

parameter settings, *72*  
programming, *66*  
protection, *135*

## R

READ\_PARAM, *91*  
READ\_STS, *91*  
resetting to zero, *95*  
RESTORE\_PARAM, *91*

## S

SAVE\_PARAM, *91*

## T

T\_WEIGHING\_ISPY101, *82*  
tare, *20*  
    modifying, *60*  
    net weight, *93*  
TSXISPY101, *11*  
TSXXBTN410, *36*

## W

WRITE\_CMD, *91*  
WRITE\_PARAM, *91*

## Z

zero  
    modifying, *54*

